

Ex2

DATAMAX[®]



Printer Overview

Congratulations on your purchase of the Ex2 printer. The Ex2 hereafter referred to as 'the printer', blends quality and durability into an affordable package with state-of-the-art electronics and user-friendly features to redefine the standard in thermal printers. The printer uses a unique one button design to simplify operation, while its USB, RS232 serial, and parallel interfaces allow easy connection to your host system.

This manual provides all the information necessary to operate the printer.

To print labels or tags simply refer to the instructions included with the software you have chosen to create the labels. A Windows® printer driver can be found on our website (www.datamaxcorp.com) or on the included CD-ROM. If you wish to write a custom program, a copy of the 'Class Series Programmer's Manual' can also be found on the CD-ROM.



Printer Connections

Connecting Power

The printer is powered by an external power supply that connects as shown. Connect the power cord to the printer first and then plug the other end into a suitable AC outlet.

Use only the power supply shipped with the printer.

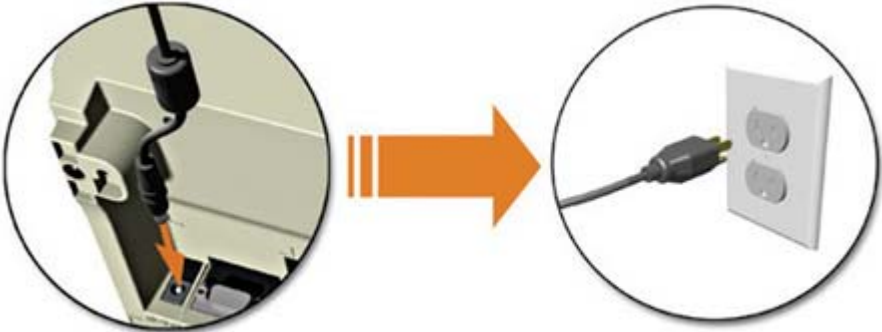

Interface Connection

The printer can be connected to the host via a USB, serial or parallel cable. The Printer will automatically connect to the first port (USB, serial or parallel) that transmits valid data. After this connection has been made, the printer's power must be cycled Off and On to change the interface connection.

USB Connection: The USB Interface is supported in Windows 95 and greater. Depending upon the operating system of your host computer, installation may differ slightly.

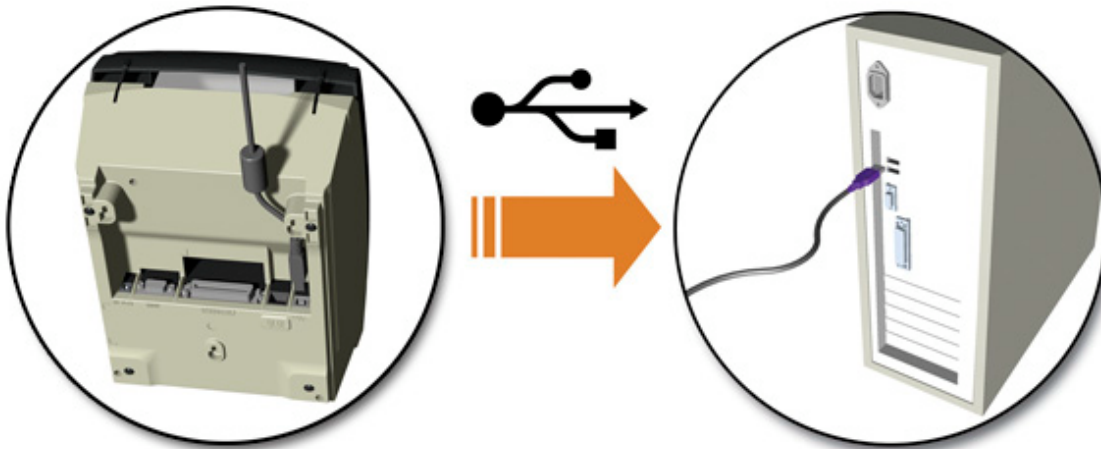

Parallel Connection: The parallel interface requires a standard parallel cable with a 36 pin male connector.

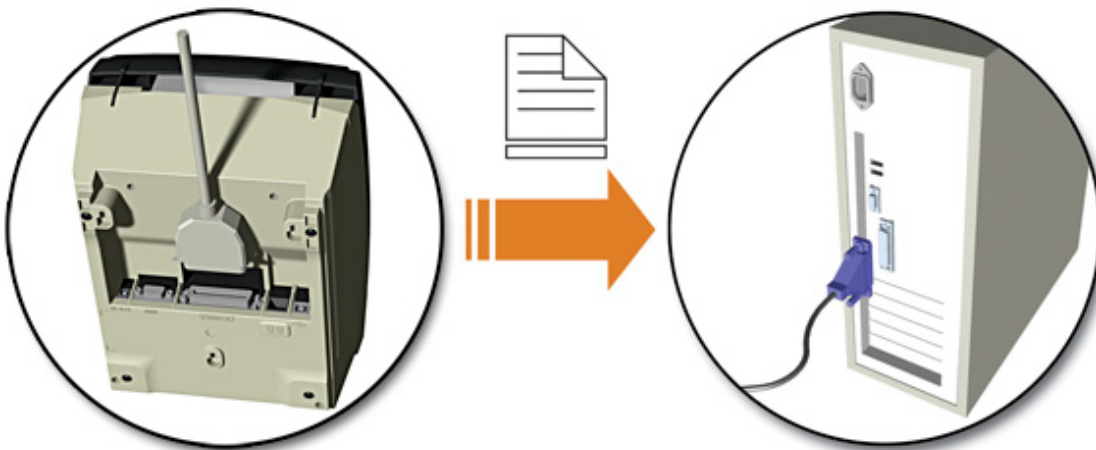

Serial Connection: The serial interface supports RS-232C communications via a DB-9 connector. The following list of serial port settings is menu-selectable and must match the host computer's serial port settings: > Baud Rate (Default 9600 bps) > Word Length (Default 8 bits)

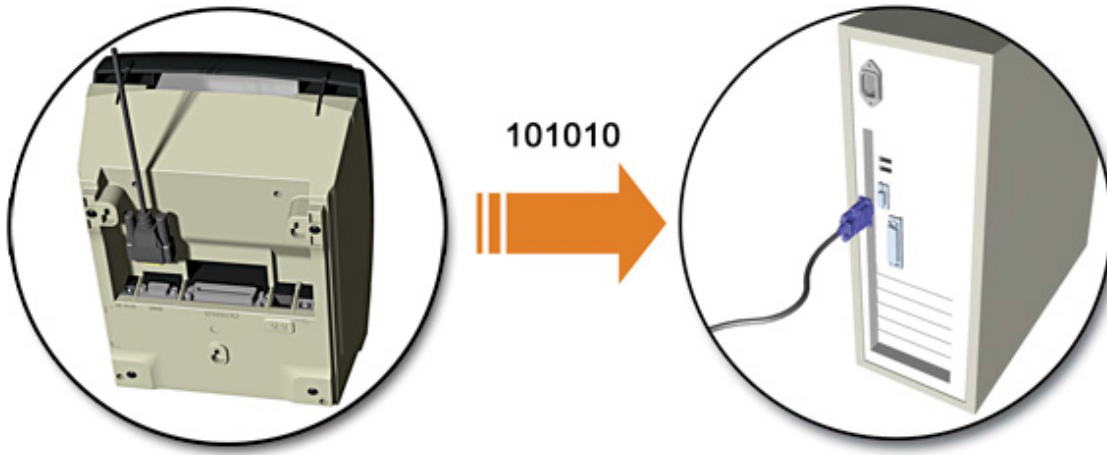

In addition to the port settings, the serial interface cable wiring must have specific connections (pin-outs) for proper data exchange between the host and printer. The different serial cable pin-outs and part numbers are shown below (contact your reseller for ordering information). An "off the shelf" serial cable can be used with Xon/Xoff handshaking.

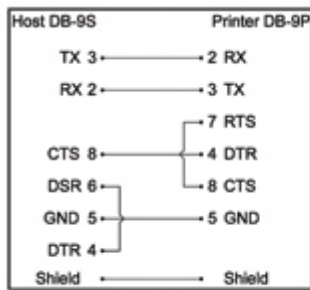

Part # 32-2300-01

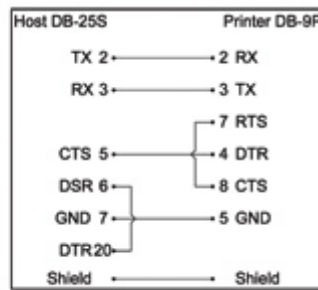

Part # 32-2301-01

Optional Internal Ethernet: When using this interface, refer to the **Ethernet Setup** section, for proper setup, and configuration.

Ethernet Setup

The printer must be assigned an IP address in order to communicate with the host/network. This can be accomplished using several methods:

- Automatically obtain an IP via a DHCP Server
- Using the Printer Configuration Utility (*DMXConfig*) to set IP values
- Using the default IP, configure settings via the printer's internal web pages

Automatically Obtain an IP via a DHCP Server

The printer is factory configured to "DHCP Enabled". When the printer is powered on it will search for a DHCP server, if found, the server will assign an IP address to the printer.

Connect the network cable to the printer and power on the printer. Allow 90 seconds (from power up) for the printer to retrieve an IP address from the server. After this time, print a Configuration Label to verify the printer's current network settings.

To print the Configuration Label:

1. Be sure the printer is properly loaded with media (at least 2 inches wide), and that the power to the printer is off.
2. Apply power to the printer, once the Status light is on press and hold the Control Button.
3. Continue to hold the Control Button until the Configuration Label starts to print.

<p>Note: After the printer has completed printing the Configuration Label the printer will enter Hex Dump Mode. To exit Hex Dump Mode simply remove power from the printer or perform a 'Printer Reset' by holding the Control Button for at least 10 seconds, then releasing.</p>

The 'NIC ADAPTER' section on the Configuration Label will list the printer's current network settings.

After 90 seconds if a DHCP server is not found the printer will fall back to its default network settings of:

IP Address: 192.168.10.2
Subnet Mask: 255.255.255.0
Gateway: 0.0.0.0

If the DHCP retrieval was successful, a new IP address value should be shown. This IP address can then be used to browse to the printer's internal web pages for further configuration or used for installing the Windows Driver.

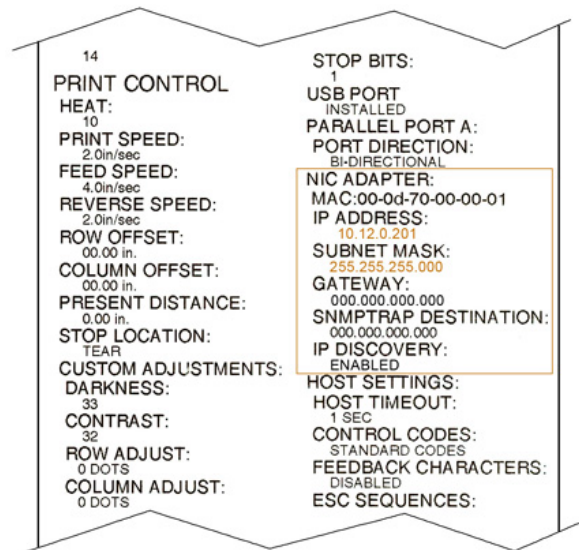

Using the Printer Configuration Utility (DMXConfig) to set IP values

1. Connect the printer to the host via the parallel or serial port
2. Start the DMXConfig program, see the [Printer Configuration Utility](#) section for installation.

3. Click "Query Printer" Button – This will retrieve the printer's current configuration.

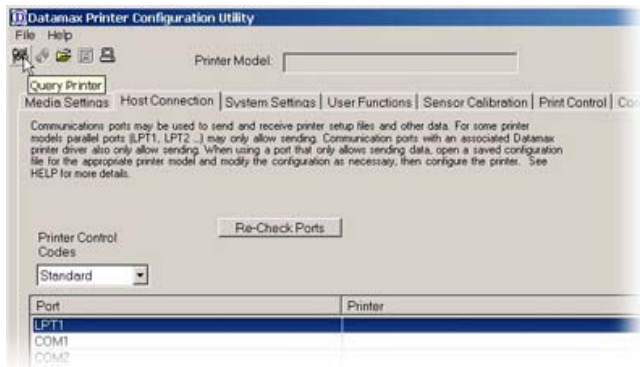

4. Click on the “Communications” Tab, scroll to bottom for IP settings.

5. Set the IP, Mask, Gateway to your desired values.

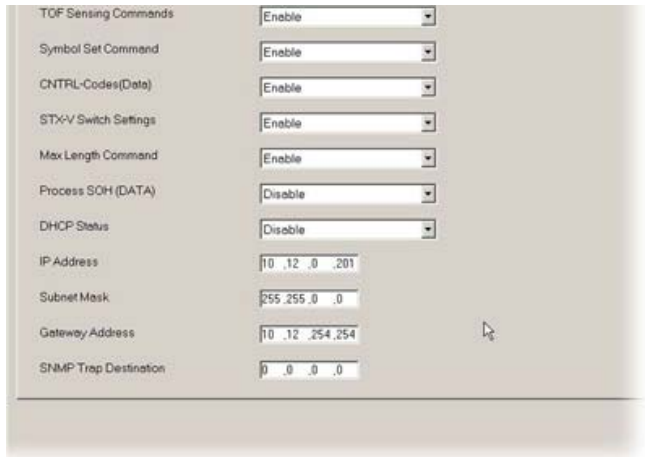

6. Click the ‘Configure Printer’ button to send the changed values to the printer.

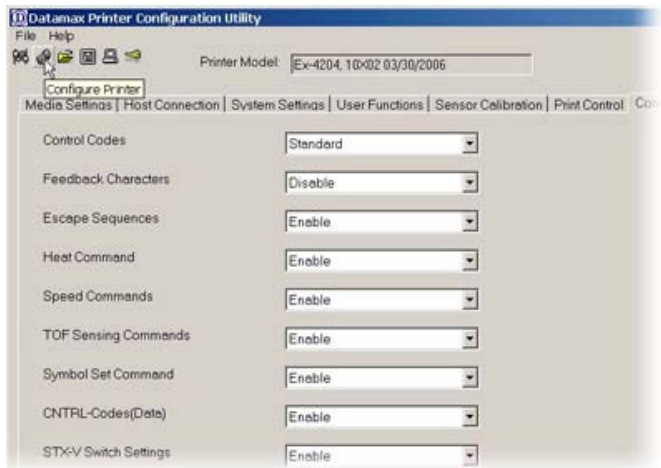

7. Go to “User Functions” Tab and click the “Print Configuration” Button to confirm the printer has received the new values.

8. Exit the DMXConfig program.

9. Power Off the printer and remove the parallel or serial connection. Connect the network cable to the printer and power on the printer.

The new IP address can then be used to browse to the printer's internal web pages for further configuration or used for installing the Windows Driver.

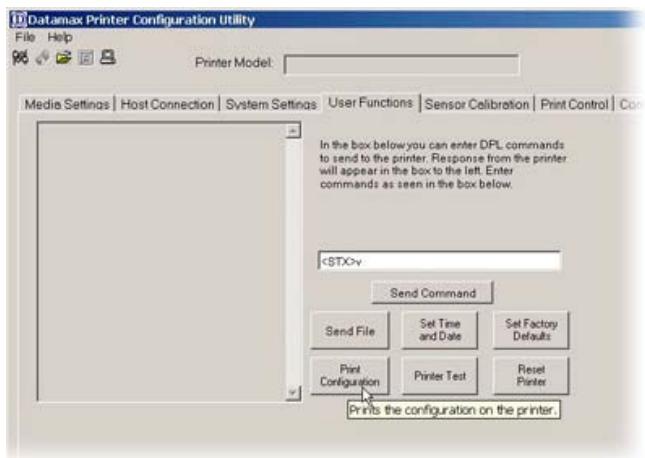

Configure Settings via The Printer's Internal Web Pages

The printer is factory configured to the default network settings of:

IP Address: 192.168.10.2

Subnet Mask: 255.255.255.0

Gateway: 0.0.0.0

If these values are in range of your network, (*if you are unsure contact your system administrator*), you can browse directly to the printer's internal web pages by entering this IP address into a web browser.

1. Connect the network cable to the printer and power on the printer.
2. Open a web browser such as "Internet Explorer". Type the default IP address (192.168.10.2). The printer's internal web pages should appear:



The screenshot displays the printer's internal web interface. On the left, there is a navigation menu with the following items: Unit Information (selected), Network Status, TCP/IP Configuration, System Settings, Media Settings, Print Control, Printer Options, Communications, Diagnostics, Network Print Options, Reset Network Parameters, Change Password, and About Datamax. The main content area is titled "Unit Information" and contains a table with the following data:

Printer	E-Class 4203
Printer Status	Idle
Error Message	
Printer Message	READY
Application Version	83-2561-10A 10X02 04/05/2006
Printer Key	4203-EF10-000000-046
Boot Loader Version	83-2560-10A 10.00
MAC Address	00 0D 70 FF FF FF
Network Speed	100 Megabits/sec
FPGA Version	-

3. Click on the "TCP/IP Configuration" tab.

E-CLASS

TCP/IP Configuration

Static IP Settings

IP Address: 10 . 12 . 0 . 180

Subnet Mask: 255 . 255 . 0 . 0

Default Gateway: 10 . 12 . 254 . 254

DHCP Settings

Enable IP Discovery (DHCP, BOOTP, etc.)

Wireless Settings

Enable Wireless

Port Number: 9100

SNMP Trap Destination Address: 0 . 0 . 0 . 0

NetBIOS (WINS) Settings

NetBIOS Name: DMX_FFFFFFFF

Primary WINS Server: 0 . 0 . 0 . 0

Secondary WINS Server: 0 . 0 . 0 . 0

A password is required to perform this function

Apply Clear

4. Set the IP, Mask, Gateway and other network settings to your desired values.

5. Type the Authentication password (sysadm) into the box on the bottom of the page and click on "Apply" to apply the changes.

The new IP address can then be used to browse to the printer's internal web pages for further configuration or used for installing the Windows Driver.

Loading Media

Installing the Media Roll

Note: The Media Guides must be adjusted to match the width of the media you are using, (see [Media Guide Adjustment](#)). Once the Media Guides are set for the width of the media being used it is no longer necessary to perform this adjustment.

Note: It is important that the Windows Printer Driver 'Stock' setting matches the size of the label you are using. See the [Windows Driver](#) section.

1. Slide the Media Hanger Guides outwards until they lock in place.

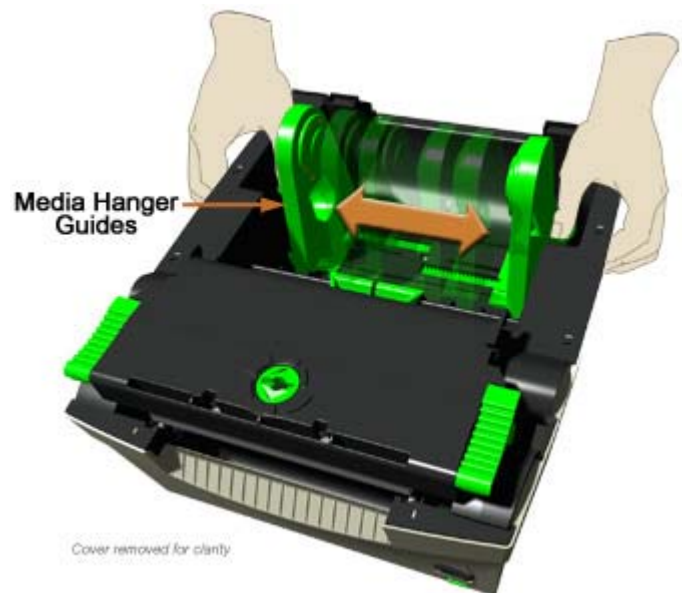

2. Insert the roll of Media as shown.
Gently push the left Media Hanger Guide toward the rear of the printer so that it releases from the Catch. The Guides will then retract and grasp the media roll.

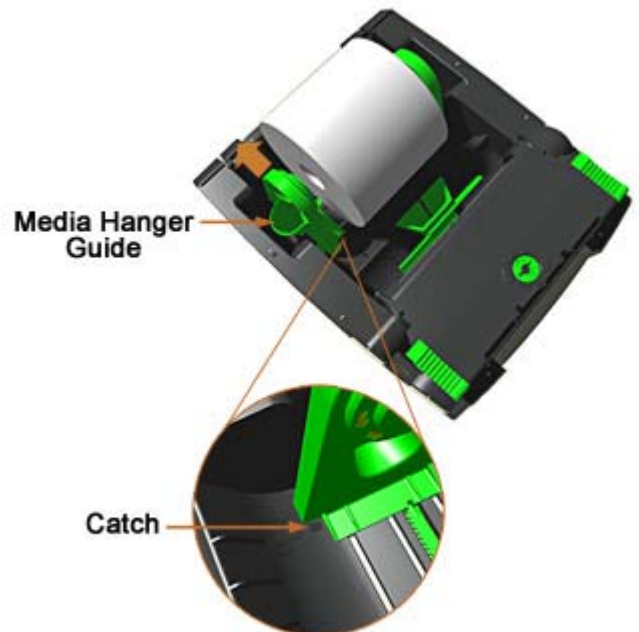

3. Feed the media forward into the printer. Once the media is detected the printer will grab the media and position it for printing.



Loading the Peel and Present Option

Note: The Present Sensor can be used with the tear bar instead of using the peel feature. For this configuration simply complete steps 1 and 2 only.

1. Open the Peel and Present Door. Set the Peel and Present switch to the '1' position.
2. Complete the 'standard' media loading as described in the previous section.
3. Feed approximately 12 inches of media out of the printer and remove the labels from the media liner.
4. Route the media liner over the Peel Bar, behind the Rollers, and out of the opening beneath the Peel and Present Door as shown.

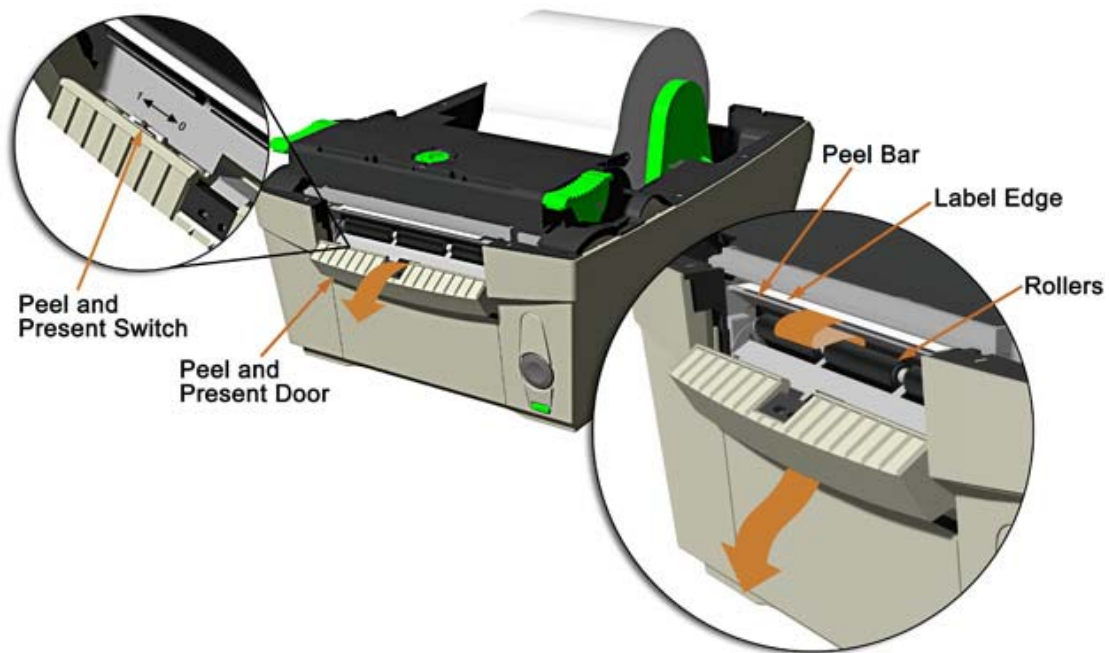

5. While pulling firmly on the Media Liner, close the Peel and Present Door. It is important to keep the Media Liner taught around the Peel Bar.

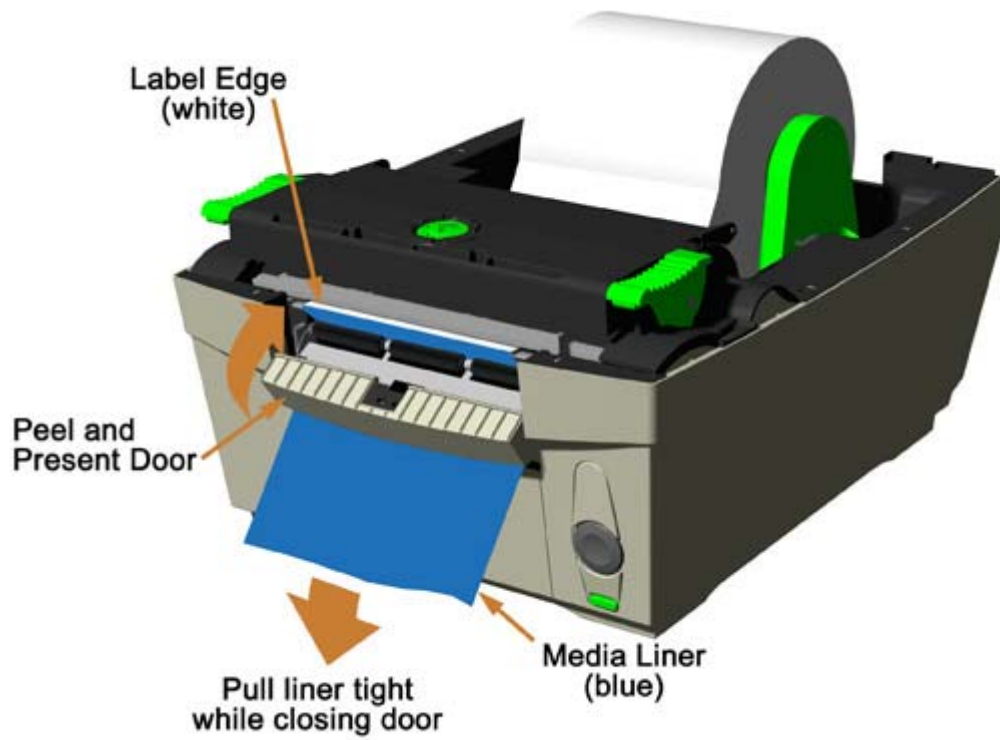

Fan-fold / External Supply Loading

With the Media Hanger Guides in their centered position, route the media through the Slot in the Cover, over the Hanger Guides, and into the properly adjusted media guides.

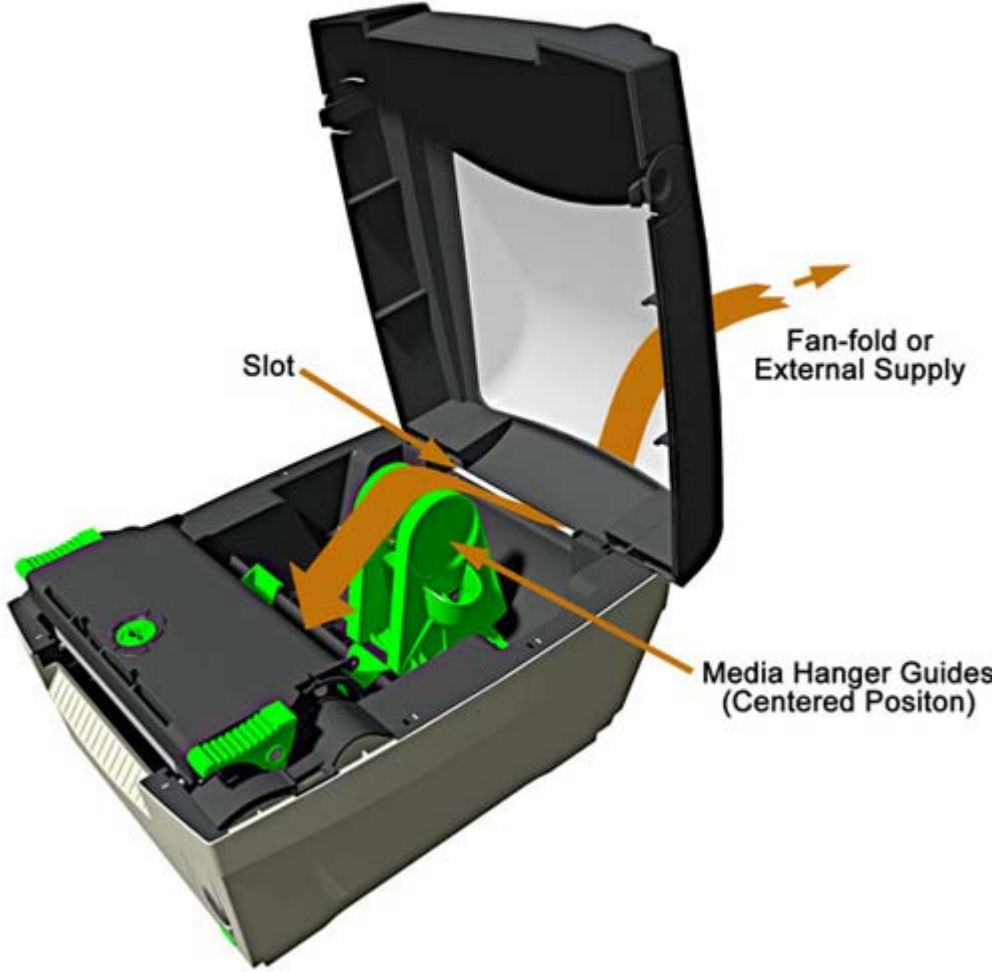

Media Setup

The printer's default setup is for die-cut label media, 4" (101.6mm) wide. Reflective label media (black mark) and Continuous label media (no black mark, holes, gaps etc.) may be used by configuring the printer appropriately using the Windows Printer Driver or Printer Configuration Utility (DMXConfig), both provided on the Accessories CD. Consult the help files found in these programs for additional information.

Continuous Label Media

Media Setup – Windows Printer Driver:

Driver setup is required for any software application that uses the Windows Printer Driver. This setup only provides the printer with dynamic settings that are lost when power is removed.

Step	Action	Comments
1	Printer driver setup	Printing Preferences from the General tab on the driver provides the proper controls to setup for the desired label media. From there, the Page Setup tab must be selected to specify the label size, width and length. The Stock tab is where the label type is controlled. Media Control, Label Sensor, provides appropriate selections for the label type in use. Select Label Sensor Disabled for continuous label media.
2	Load labels	Loading continuous labels will, depending on its reflectance levels, may result in a Top of Form fault. This is normal; printer drivers do not configure the printer until a label is sent to be printed.
3	Create label format	Using any Windows application, create a label format. Ensure that the page size selected in the application software is the same as that configured in the printer driver.
4	Print the label	The printer will continue to flash the Status Light indicating a fault.
5	Press the Control Button	This will clear the fault, feeding the selected label length, and then print the label.

On subsequent printer power-ups, if the media has not been removed, simply print the label as outlined in steps 3 and 4.

Note: To configure the printers "power-up" settings use the [Printer Configuration Utility](#) (DMXConfig) included on the Accessories CD-ROM. Using this method will result in less label waste when loading continuous label media

Reflective Mark Label Media

Media Setup – Windows Printer Driver:

Driver setup is required for any software application that uses the Windows Printer Driver. This setup only provides the printer with dynamic settings that are lost when power is removed.

Step	Action	Comments
1	Printer driver setup	Printing Preferences from the General tab on the driver provides the proper controls to setup for the desired label media. From there, the Page Setup tab must be selected to specify the label size, width and length. The Stock tab is where the label type is controlled. Media Control, Label Sensor, provides appropriate selections for the label type in use. Select Label Sensor 'Label Mark' for reflective label media.
2	Load labels	Loading reflective label media will, depending on its reflectance levels, may result in a Top of Form fault. This is normal; printer drivers do not configure the printer until a label is sent to be printed.
3	Create label format	Using any Windows application, create a label format. Ensure that the page size selected in the application software is the same as that configured in the printer driver.
4	Print the label	The printer will continue to flash the Status Light indicating a fault.
5	Press the Control Button	This will clear the fault, feeding the selected label length, and then print the label.

On subsequent printer power-ups, if the media has not been removed, simply print the label as outlined in steps 3 and 4.

Note: To configure the printers "power-up" settings use the [Printer Configuration Utility](#) (DMXConfig) included on the Accessories CD-ROM. Using this method will result in less label waste when loading continuous label media

Printer Operation

The printer is equipped with a single multi-function Control Button and Status Light.



Status Light 'On' (Normal Operation)

With the status light in the ON state the **control button** will function as follows:

Printer at Idle - Printer feeds media to the next label.

Printing Labels - Pauses Printer, press again to resume.

Status Light 'Flashing' (Paused or Error Condition)

The status light flashing indicates that operator attention is required. In this state the **control button** will function as follows:

Printer is Paused - Printer resumes normal operation;

- Press and hold for 3 seconds to cancel current print job.

Error Mode - Clears error, feeds media to next label and resumes operation.

Printer Reset

The printer can be reset by pressing and holding the Control Button for at least 10 seconds, then release the button, the Status Light will turn off momentarily. Resetting the printer will clear RAM of downloaded images, fonts, label formats, and remove temporary printer configuration changes.

Maintenance Mode

Initiation of this mode causes the printer to print its Configuration Label and to begin the Hex Dump Mode.

The Configuration Label provides valuable printer information including the firmware version, memory allocations, enabled options, communications settings, and label-counter data.

To print the Configuration Label:

1. Be sure the printer is properly loaded with media (at least 4 inches wide), and that the power to the printer is off.
2. Apply power to the printer, once the Status light is on press and hold the Control Button.
3. Continue to hold the Control Button until the Configuration Label starts to print.

After the printer has completed printing the Configuration Label the printer will enter Hex Dump Mode. In this mode, all data sent to the printer will be immediately output in hexadecimal code, along with the printable ASCII equivalents. The Hex Dump Mode is a useful tool for advanced users in the diagnosis of problems including communications, handshaking, and DPL syntax errors. To decode this information, the Programmer's Manual is an essential reference.

To exit Hex Dump Mode simply remove power from the printer or perform a 'Printer Reset' by holding the Control Button for at least 10 seconds, then releasing.

Windows Driver

The Windows driver is located on the Accessories CD-Rom included with your printer. For the latest version please visit our web site at www.datamaxcorp.com.

Installing the Windows Driver:

Place the Accessories CD-Rom included with your printer into your computers CD-Rom drive.

Once the CD-Rom starts, select "Windows Printer Drivers" from the main menu and then click the "Install" button.



The Windows "Add Printer Wizard" will begin. Follow the steps in the wizard to complete the driver installation.

When prompted for the driver file, select 'Have Disk' and browse to the following file on the CD-Rom:

Windows 95, 98, ME, 2000, and XP:

"D:\DRIVERS\Seagull\Datamax for 95, 98, me, 2000, and xp.inf"
(Where D: is your CD-Rom drive)

Windows NT4.0:

"D:\DRIVERS\Seagull\NT4\Datamax for nt 4.0 only.inf"
(Where D: is your CD-Rom drive)

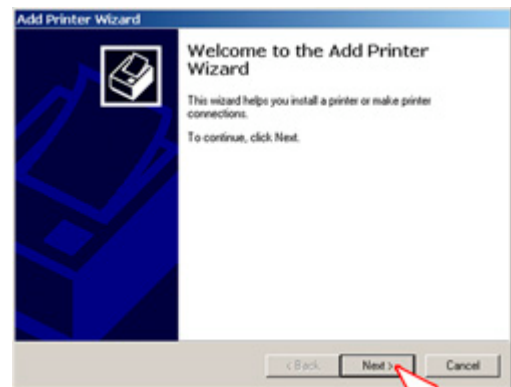

Important Notes:

The Windows driver functions the same as any other Windows printer. A built in help file is available for complete information on all settings, however there are some important settings that should be observed for trouble free printing.

Page Setup Tab: Stock

It is important that the Stock setting matches the size of the label you are using. If you cannot find a match for your label click 'New' and enter the dimensions of your label.

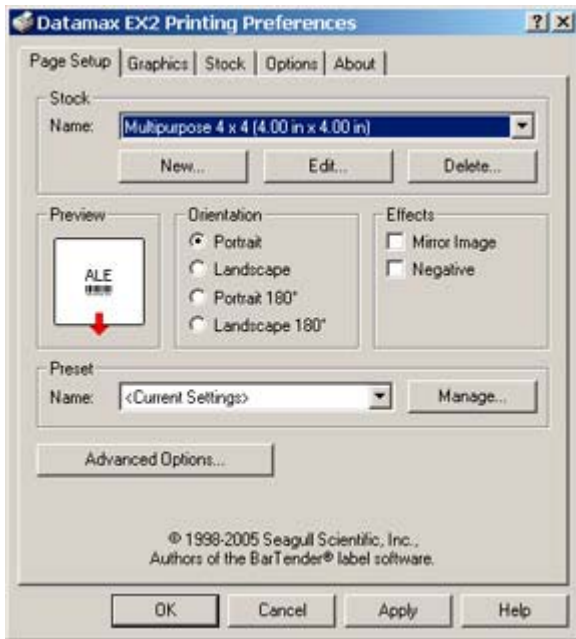

Options Tab: Print Speed & Printhead Temperature

These two settings will have the greatest effect on print quality. Some label stocks will require more heat and slower print speeds to generate a quality image.

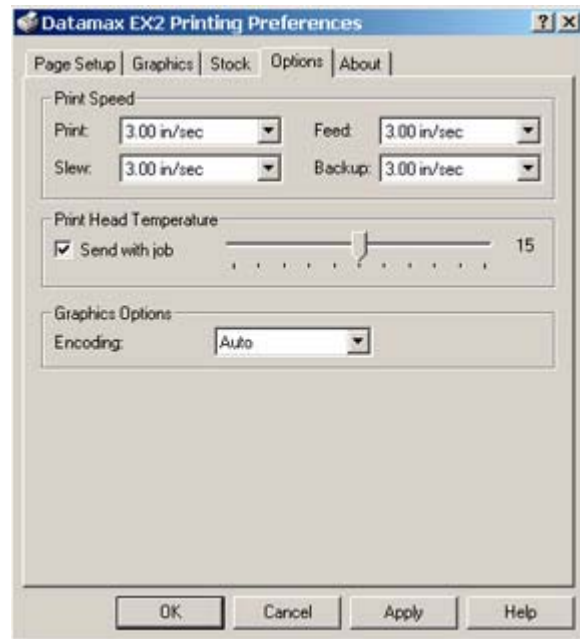

The Windows application software used to create the label format will likely have a "Page Setup" screen. This will also need to match the size of the label you are using.

Printer Configuration Utility (DMXConfig)

DMXConfig (located on the Accessories CD-ROM) is a windows based configuration utility that allows the user to make changes to the existing printer setup via a direct connection to the host computers serial and parallel connection or any port (USB, Ethernet, ect.) assigned to a Datamax printer driver port.

DMXConfig Features:

- > Allows Real-Time Control/Query of Printer Configuration
- > Define and Save Optimal Configurations for Applications
- > Saved Configurations can be Shared with other Printers and Sent via Email
- > Download Files, Formats and Fonts
- > Query Memory Modules

Note: Be sure to use the DMXConfig utility located on the Accessories CD-Rom that is included with your printer. Older versions might not operate correctly with some printers. For the latest version please visit our web site at www.datamaxcorp.com.

Installing DMXConfig:

Place the Accessories CD-Rom included with your printer into your computers CD-Rom drive.

Once the CD-Rom starts, select "Printer Configuration Utility" from the main menu and then click the "Install" button.

The DMXConfig setup program will begin. Follow the steps to complete the program installation.



Maintenance and Adjustments

Cleaning Intervals

The following table outlines the recommended maintenance schedule for the various printer parts.

Area	Method	Interval
Printhead	Turn off the printer before cleaning the printhead. Use solvent* on a cotton swab to clean the printhead from end to end.	After every roll of media.
Platen Roller	Turn the power off. Remove the platen roller and clean it thoroughly with solvent* and a cotton swab.	After every roll of media.
Peel-Off Rollers	Rotate the peel-off rollers and clean it thoroughly with solvent* and a cotton swab.	After every roll of media.
Media Path	Solvent*	After every roll of media.
Peel/Tear Bar	Solvent*	As needed
Media Sensor	Compressed Air	Monthly
Exterior	Mild detergent or desktop cleaner.	As needed
Interior	Brush or vacuum	As needed.

* It is recommended that a solvent containing isopropyl alcohol be used.

	<p>Isopropyl alcohol is a flammable solvent, always take the proper precautions when using this substance.</p>
---	--

Printhead Cleaning

If print quality declines (symptoms include non-compliant bar codes, print dropouts, streaks), the typical cause is debris build-up on the printhead. Furthermore, when the build-up is not removed it may lead to element failure, greatly reducing the life of the printhead. To clean the printhead:

1. Unplug the printer.
2. Open the cover. Press down on the Printhead Latches and raise the Printhead Carrier.

	Allow the printhead to cool before proceeding.
---	--

3. Using a Cotton Swab moistened, not soaked, with isopropyl alcohol gently wipe away any build-up on the printhead surface, paying close attention to the Burn Line. Allow the printhead to dry.

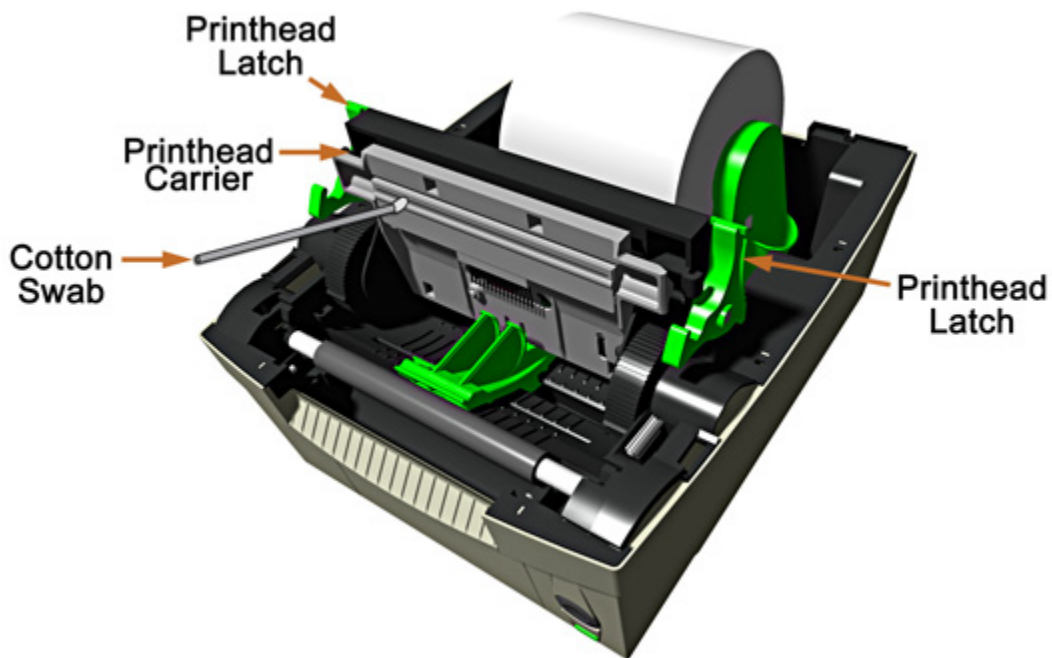

4. Lower the Printhead Carrier back to the down and locked position.
5. Close the cover. Plug in the printer. Feed several labels to normalize tracking.

Printhead Pressure Adjustment

To accommodate a variety of media types, the pressure applied by the printhead assembly is adjustable. This pressure is factory set to work with most media types, so this adjustment should only be performed after attempting to improve print quality through the use of the (1) heat and/or (2) print speed software controls.

When adjusting, use only the minimum pressure necessary for better imaging. To adjust:

1. Load the printer with media, see ['Loading Media'](#).
2. Print a test label from the host.
3. Using a small coin or screwdriver, turn the Printhead Pressure Adjustment Screw so the arrows point to the desired setting:

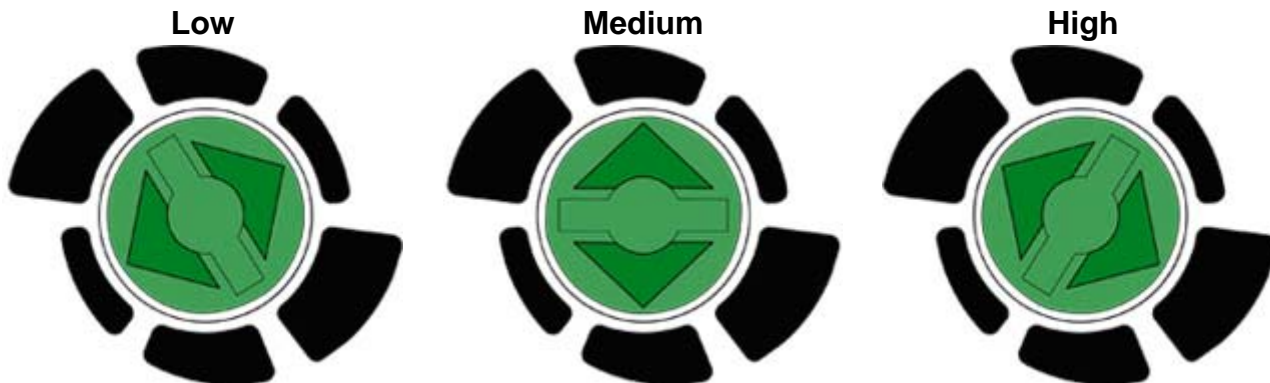
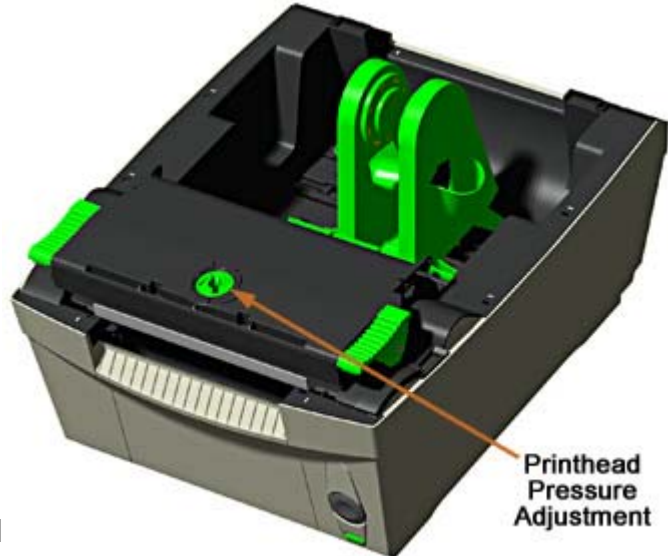

Note: Excessive pressure can reduce the service life of the printhead and platen roller.

Media Guide Adjustment

Note: It is important that the Windows print driver 'Stock' setting matches the size of the label you are using. See the [Windows Driver](#) section.

1. Unplug the printer from its power source.
2. Press down on **both** Printhead Latches to unlock the Printhead Carrier. Raise the Printhead Carrier to its up position.

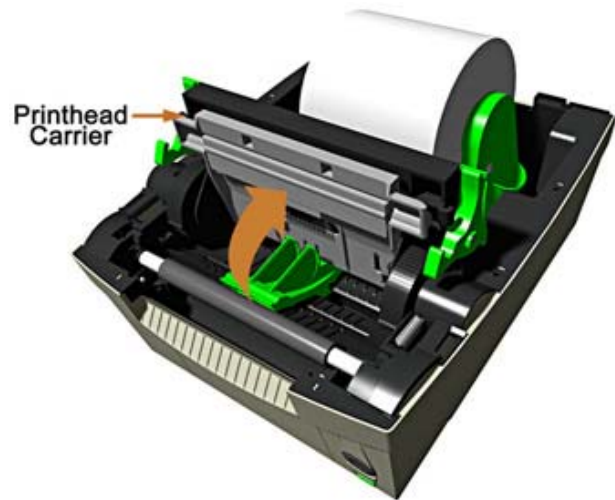
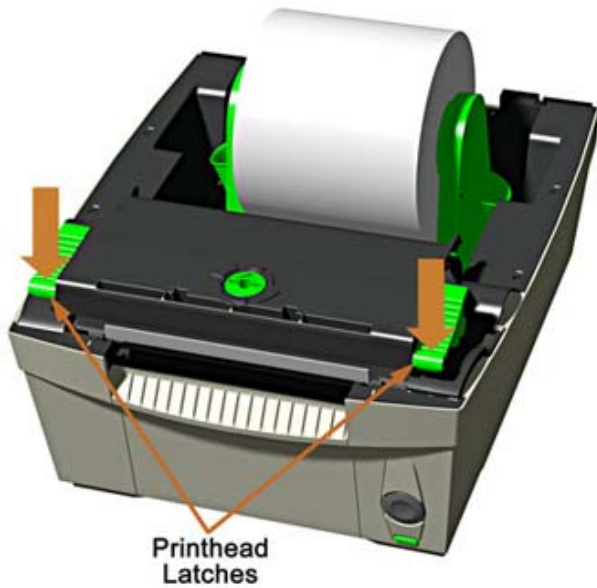

3. Adjust the Media Guides to fit the width of your media. The guides should be positioned so that there is very little side-to-side media movement, but not so tight as to cause friction or bowing of the media.

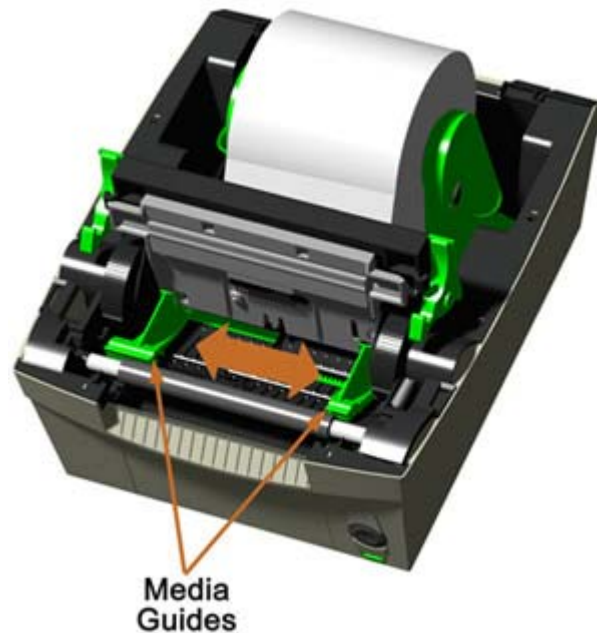



Too Tight



Correct



Too Loose

4. Close and latch the Printhead Carrier. The printer is now ready to be loaded with media, (see [Loading Media](#))

Printhead Removal/Replacement

Note: Printheads are fragile; use extreme care when handling and never use a sharp object on the surface. If you have questions, contact a qualified technician or Datamax Technical Support before proceeding.



Allow the printhead to cool before proceeding.

1. Unplug the printer. Open the cover.
2. With the printhead locked in the down position, loosen the Printhead Mounting Screw (it will remain in the assembly).

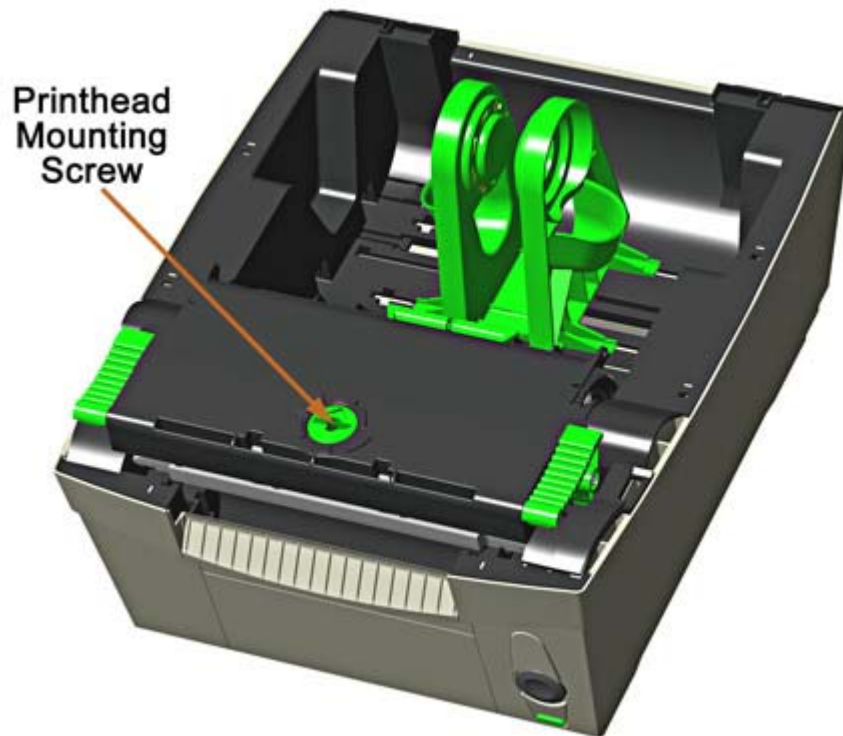

3. Press down on the Printhead Latches and raise the Printhead Carrier. Disconnect the Printhead Cable and then remove the Printhead.

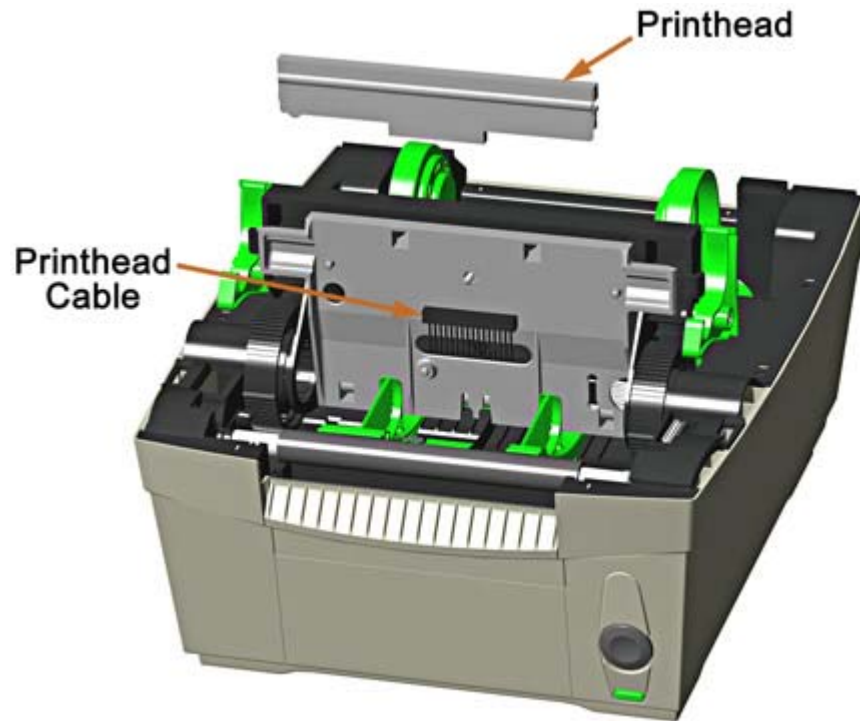

4. While carefully holding the new Printhead, connect the Printhead Cable.
5. Position the Printhead onto the Locating Pins in the Printhead Assembly and secure in place with the Printhead Mounting Screw (do not over-tighten).
6. Clean the Printhead.

Platen Roller Removal/Replacement

The Platen Roller can be easily removed for cleaning, replacement, or clearing media jams.

1. Unplug the printer.
2. Open the cover. Press down on the Printhead Latches and raise the Printhead Carrier.
3. Rotate the Platen Roller Latches 90 degrees to their 'Up' position.

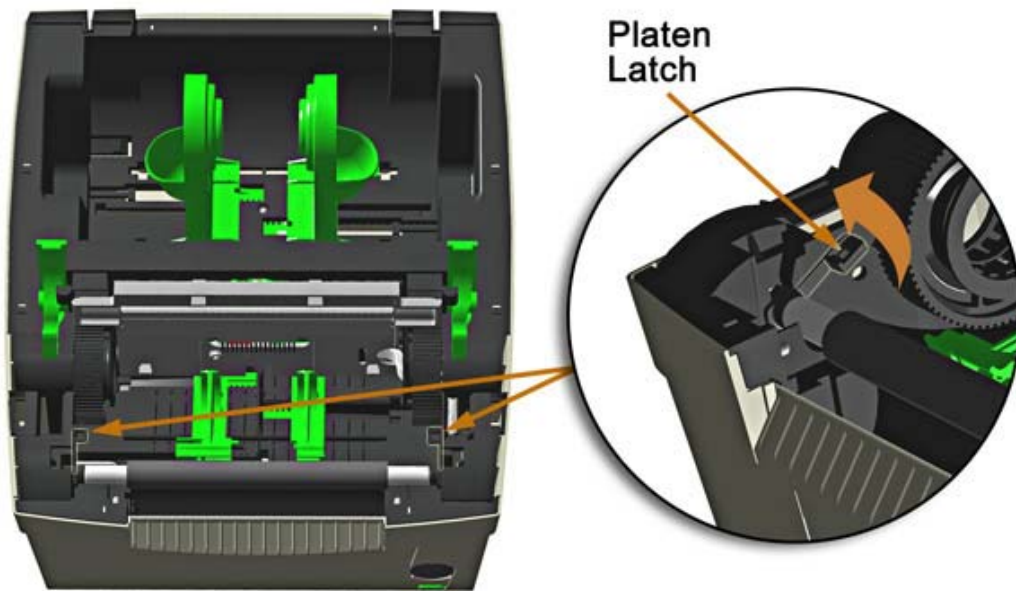

4. Grasp both of the Platen Roller Latches and pull the Platen Roller out of the printer.

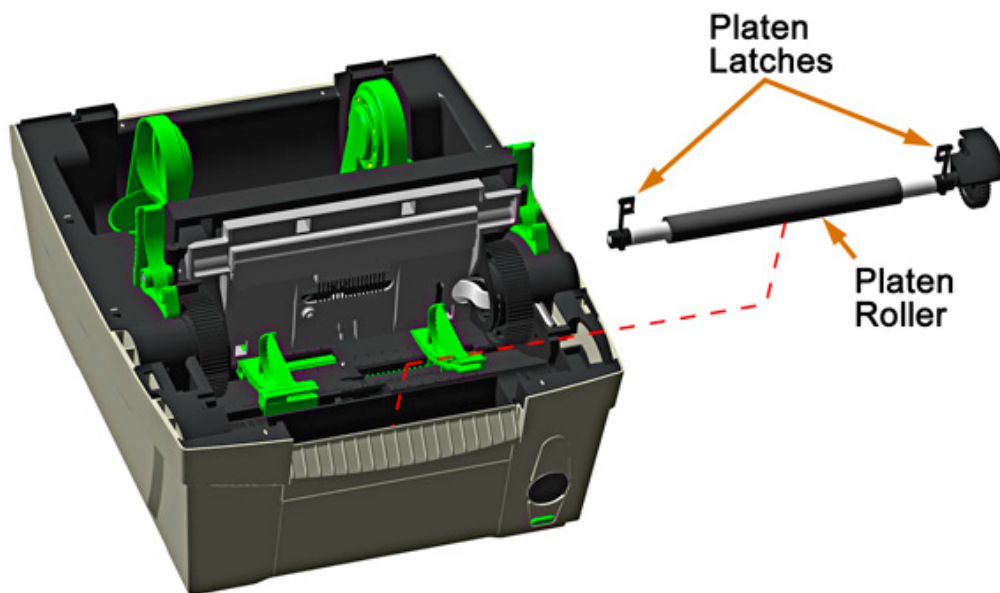

5. The Platen Roller can now be cleaned or replaced. When replacing be sure the left Platen Latch is oriented correctly, with the handle portion towards the middle of the printer.

Downloading Firmware and Fonts

The operating programs and fonts for the printer are stored in Flash memory on the main PCB. When program updates and/or new features are added, they can be downloaded to the printer as follows:

1. Identify the new version for your model of printer from the [Datamax Web site](#) and download it onto your computer's hard drive or a floppy disk.
2. Ensure that the printer is connected to the host, (via parallel port or USB only, serial port not recommended due to slow transfer speed) and that the power is 'On.'
3. From the Windows printer driver Properties box select the 'Tools' tab and then select 'Send File to Printer' from the 'Action' drop-down box.
4. When prompted browse to the new firmware/font file on your computers hard drive.
5. The Status Light will flash as the data is received. Following a successful download, the printer will perform a 'cold reset.' The previous printer setup will not be affected unless substantial firmware data structure changes have occurred.

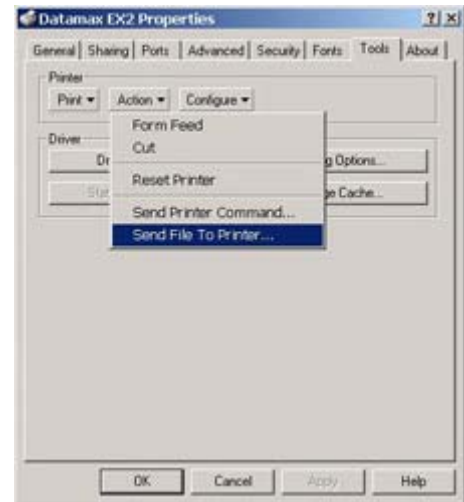

Print a Database Configuration Label via the Windows printer driver to verify your new firmware version.

Following an unsuccessful download, the printer will perform a 'warm reset'. The original firmware will remain operational. If the printer fails to reset, toggle the power Off and On. Try re-sending the file to the printer. If the failure continues, check the following possible causes:

- > An invalid or corrupted file is being downloaded - Ensure the file being downloaded is correct and applicable for your printer model.
- > Possible communications error - Check the cable connection between the host and printer and ensure that a quality, shielded cable is used.
- > Possible Flash memory problem - Call for service.

Troubleshooting

Occasionally, situations arise that require troubleshooting. Possible problem situations and potential solutions are listed in this section. While not every situation is addressed, you may find some of these tips helpful. After the corrective action is taken press the Control Button to clear the alarm. Contact a qualified service technician for problems that persist or are not covered in this section.

<i>If experiencing this problem...</i>	<i>Try this solution...</i>
No power, Status light is 'Off':	<ul style="list-style-type: none"> • Verify that the AC power cord connection has been made at both the outlet and the printer. • Verify that the AC outlet is functioning, or try moving the printer to another AC circuit. • The AC cord or External Power Supply may be damaged; replace it.
Will not print, Flashing LED:	<ul style="list-style-type: none"> • Printer is paused; Press the control button. • Out of stock fault detected; Ensure the media guides are set to a width appropriate for media being used. • Top of form fault detected due to missing label(s). Maximum label length has been exceeded before detecting a label edge; Check for properly load media and press the control button to feed to next label. • Top of form fault detected due to improper Top of Form sensing selection; Change sensing appropriate for the media in use with printer driver properties or using Datamax Printer Configuration Utility (DMXConfig). • Top of form fault detected due to improper Maximum Label Length for media in use; Consider increasing Maximum Label Length using Datamax Printer Configuration Utility (DMXConfig). • Top of form fault detected due to improper Top of Form Sensor calibration for media in use; Consider performing Top of Form Sensor Calibration using Datamax Printer Configuration Utility (DMXConfig).
Will not print, LED ON:	<ul style="list-style-type: none"> • Present sensor is enabled but the Present sensor switch is in the OFF position; Move the present sensor switch to the ON position. • Presented label detected; Remove presented label. • No communication from host computer to printer; Check cable connections and printer driver setup/port selection.
Printer attempts to print with motor "groaning noise":	<ul style="list-style-type: none"> • Label backing wrapped around platen roller; Remove platen roller, clear jam, and press control button. • Incorrect Power Supply; be sure to only use the power supply shipped with the printer.
Start of print registration not consistent:	<ul style="list-style-type: none"> • Media guides positioned too wide for media; Adjust media guides firmly against the edges of the media.

<i>If experiencing this problem...</i>	<i>Try this solution...</i>
Present sensor not functioning, labels continue to print uninterrupted:	<ul style="list-style-type: none"> • Present sensor switch in OFF position; Move present sensor switch to the ON position. • Present sensor disabled; Change the present sensor operation to enable using the Windows printer driver properties or Datamax Printer Configuration Utility (DMXConfig). Ensure present sensor switch set to ON.
Printer attempts to load with no media installed:	<ul style="list-style-type: none"> • Debris in label edge sensor; Air blow out debris, clean with alcohol and lint free material. • Out of Stock setting is too low; Run Quick Media Calibration using Datamax Printer Configuration Utility (DMXConfig). • Out of Stock setting is too low; Increase OOS Maxvolt using Datamax Printer Configuration Utility (DMXConfig).
Media not auto-loading while motor attempts to load:	<ul style="list-style-type: none"> • Leading edge of media is rough, catching in Label Edge Sensor, or preventing label from engaging onto platen roller; Cut a clean leading edge at or just prior to leading edge of label. Reinsert leading edge of the media into label guides, feed the media into the guides until motor begins to move. • Out of Stock setting is too low; Increase OOS Maxvolt using Datamax Printer Configuration Utility (DMXConfig).
Media not auto-loading; motor makes no attempts to load:	<ul style="list-style-type: none"> • Media inserted before printer ready; Remove media from label guides and reinsert.
Erratic feeding:	<ul style="list-style-type: none"> • Media sensor may require cleaning; the media sensor is located in the left media guide towards the front of the printer. • The printer may require Top of Form Calibration; Perform the Calibration Procedure via the DMXConfig program.
Erratic printing (instead of the label format, strange characters are printed):	<ul style="list-style-type: none"> • The printer may be in Hex Dump Mode; Unplug the printer for 5 seconds and then reconnect power. • If using the serial port for communicating, check both the host and printer port settings; the printer may be set to eight data bits while the host is set to 7 (or vice versa).
Intellifont will not print:	Intellifont format is Little/Big Endian specific. The printer uses Big Endian. Refer to your font supplier for information.
Light print on the label:	<ul style="list-style-type: none"> • Printhead not latched; Press down on printhead to assure it is in its locked down position. • The Printhead Pressure may be incorrectly adjusted; click here to adjust. • The Printhead or Platen Roller may be dirty or worn; clean or call for service. • Incorrect Power Supply; be sure to only use the power supply shipped with the printer.

<i>If experiencing this problem...</i>	<i>Try this solution...</i>
Missing information in the printed label:	<ul style="list-style-type: none"> • Check the label format for character placement outside the dimensions of the label; all row/column values must allow enough space for the height/length of the characters and bar codes to be printed within the format size. • The available memory may have been exceeded by the memory requirement of the label format. Try reducing the memory allocated to either the internal module or scaleable font caches. • If using serial communications, ensure that the interface cable meets the requirements found in the Printer Specifications section.
Missing print on left or right side of the label:	Information may be formatted outside the label dimensions. Check your software program or driver label size settings.
Nothing is printing (labels advance normally, but no image is printed):	<ul style="list-style-type: none"> • Verify that the media was properly loaded per the Loading Media section. • The heat setting may be too low. Make an adjustment in the software program or through the Windows printer driver. • Be sure you are using Direct Thermal Media. Contact a Media Representative. • The printhead or printhead cable may be loose; unplug the printer then reconnect.
Nothing happens when trying to print using a software program:	<ul style="list-style-type: none"> • Ensure that the printer is selected in the applications 'Print Dialog Window'. • Ensure that the printer is ready and not in an alarm state. • Ensure the interface cable meets the requirements found in the Printer Specifications section.
Poor print quality:	<ul style="list-style-type: none"> • The printhead may need cleaning. • Adjust the Heat and Print Speed settings through the Windows Driver. • The media you are using may not be compatible; contact a Media Representative. • The Printhead Pressure may be incorrectly adjusted; click here to adjust. • The Platen Roller may be dirty or worn; clean or call for service. • The Printhead Burn Line may need adjusting; call for service.
Skips labels when printing:	<ul style="list-style-type: none"> • Media Calibration may be needed; Perform the Calibration Procedure via the DMXConfig program. • The label format may be within 1/8 inch of the label's trailing edge. Try reducing the size or move the format slightly. • The Printer may be configured for 'Continuous Media' instead of Gap, Die-Cut, or Reflective.
Unable to print rotated text:	The characters may be formatted outside the label dimensions. Ensure the row/column values provide enough room for the height of the characters or bar code to be printed. See the Class Series Programmer's Manual for details.

Additional Information

This printer offers the following standard and optional features:

Standard Features

Printing

- > Direct Thermal Printing
- > On Demand and Batch Printing
- > 203 DPI Printhead
- > AGFA Scalable Font Engine

Memory

- > 4 MB FLASH Memory (512K available to user, designated: Module B)
- > 8 MB DRAM Memory (512K available to user, designated: Module A)

Interfaces

- > USB interface
- > DB-9 RS-232 serial interface
- > Centronics® parallel interface

Operational

- > Simple, motor driven auto-loading
- > Media Tearbar, Up or Down
- > Fan-fold media compatible from the rear of the printer
- > Concealed power and interface cables for a "True Footprint"

Optional Features

Peel and Present Mechanism

An output control device that automatically separates printed labels from the backing material and allows subsequent printing to occur only after the removal of a previously printed label. Minimum label length is 0.75 inches (19 mm). Designed for ease of operation, the Peel and Present Mechanism is automatically detected, configured, and enabled when installed on the printer.

Internal Ethernet Connectivity (*Factory Installed only*)

An internal Network Interface Controller (NIC) that enables the printer to provide Ethernet connectivity.

External Media Supply Stand

The external media supply option allows the use of large media supply rolls, up to 8-inches in diameter, on 1" to 3" cores.

FLASH Memory Expansion (**requires new main PCB**)

An optional main PCB assembly is available with 8MB Flash memory expansion for International Language Printing Capability (ILPC).

ILPC

The International Language Print Capability consisting of one of the following:

- > CG-Times (western European) Scalable font
- > Kanji Gothic B Scalable font*
- > Simplified Chinese GB Scalable font*
- > Korean Hangul font*

(* requires flash memory expansion option)

Option Installation

The following table lists the available options and the recommended qualification level of the installer. For detailed information concerning a specific option, contact your dealer or Datamax Technical Support.

Experience Level for Options Installation

Option	Recommended Installer
Peel and Present Mechanism	DMX Certified Technician
FLASH Memory Expansion	DMX Certified Technician
ILPC	DMX Certified Technician

Printer Specifications

Mechanical

Width	8.6" (218.4mm)
Depth	10.4" (264.2mm)
Height	7" (177.8mm)
Weight	4.2 lbs. (1.8kg)
Operating Temperature	40° F to 95° F (4° C to 35° C) Maximum rated ambient temperature for power supply 77° F (25°C)
Humidity	10% – 95% non-condensing
AC Input Voltage	p/n 50-2024-01 - supports voltages of: 105 to 125, 60 Hz p/n 50-2034-01 - supports voltages of: 210 to 250, 50 Hz

Printing

Print Method	Direct Thermal
Print Speed	2 - 4 IPS (51 - 102 mm/s)
Resolution	203 dpi (8 dots/mm)
Tear Bar	Tear Up or Down
DRAM Memory	8MB
FLASH Memory	4MB

Media

Media Types	Roll-Fed, Die-Cut, Continuous, Fan-Fold
Media Width Range	1 – 4.12" (25 – 104.6 mm)
Max Print Width	4.09" (104 mm)
Print Length Range	.375 - 11" (9.52 - 279 mm)
Media Thickness Range	0.0025 - 0.0075" (0.064 - 0.19 mm)
Media Supply Roll Capacity	5" (127mm)

Communications

Interface	USB, RS-232 (DB-9), and Centronics Parallel
Baud Speed	600 to 38,400 bits per second (BPS)
Handshaking	Xon/Xoff, CTS, DTR
Parity	Even, Odd, or None
Stop Bits	1 or 2
Data Bits	7 or 8

Fonts

See "Embedded Fonts"

Bar Codes

See "Embedded Bar Codes"

Approved Media

To achieve optimum print quality and maximum printhead life, Datamax specifies the use of *DATAMAX*[®] brand media. These supplies are specially formulated for use in our printers; use of non-Datamax supplies may affect the print quality, performance, and life of the printer or its components.

For a current list of approved media for use in direct thermal applications, please contact a Media Representative at (407) 523-5650.

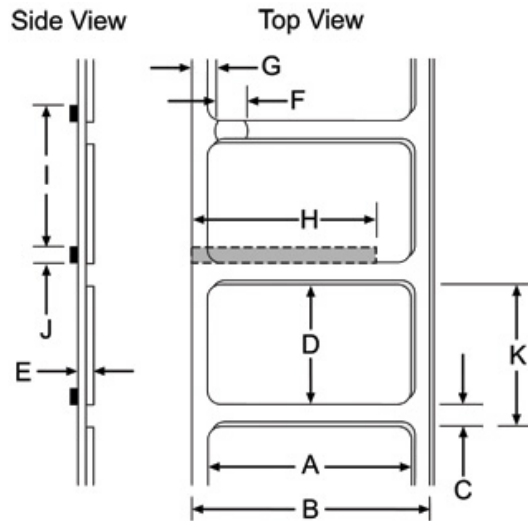

Media Dimensions			
Designator	Description	Maximum	Minimum
A	label width	4.12" (104.65mm)	1.00" (25.4mm)
B	liner width	4.12" (104.65mm)	1.00" (25.4mm)
C	gap (or notch) between labels ^[2]	.25" (6.35mm)	.100" (2.54mm)
D	label length ^[2]	–	.25" (6.35mm)
E	media thickness	.010" (.254mm)	.0025" (0.0635mm)
F	notch opening width	.500" (12.7mm)	.200" (5.08mm)
G	distance from the media's edge to the media sensor aperture (left justified)	2.25" (57.15mm)	.200" (5.08mm)
H	reflective (black) mark width ^[1]	4.12" (104.65mm)	.500" (12.7mm)
I	distance between reflective marks ^[2]	–	.125" (3.18mm)
J	reflective mark length ^[2]	–	.100" (2.54mm)
K	label repeat distance ^[2]	–	.350" (8.89mm)

[1]The reflective (black) mark must be carbon based, placed on the backside of the stock, and the reflectance shall be less than 10% at wavelengths of 950 and 640 nm.

[2] Maximum label length will vary depending on the printers memory configuration. The maximum allowable length of the combined label and gap (or mark) measurement cannot exceed 99.99 inches.

Wall Mounting

The printer's base has provisions for mounting to a wall or other sturdy vertical surface.

Be sure to use the appropriate fastener and anchor system compatible with the material of the wall you are mounting the printer to, (eg. drywall, masonry, ect.) and can support at least 20lbs (9kg).

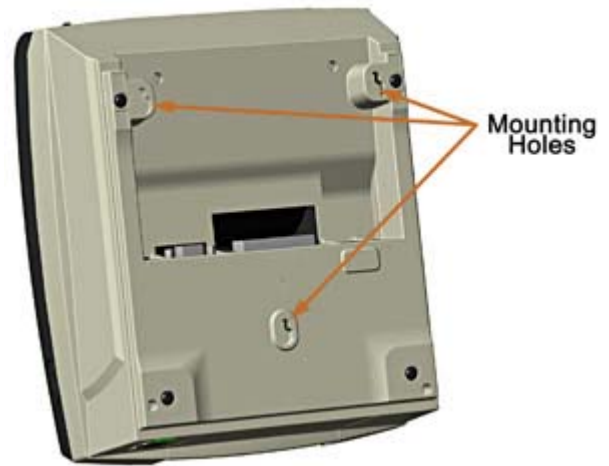

Fastener Head Diameter: 0.330" - 0.250" (8.38mm - 6.35mm)
Head Distance from Wall: 0.110" - 0.130" (2.79mm - 3.30mm)

Hole Layout

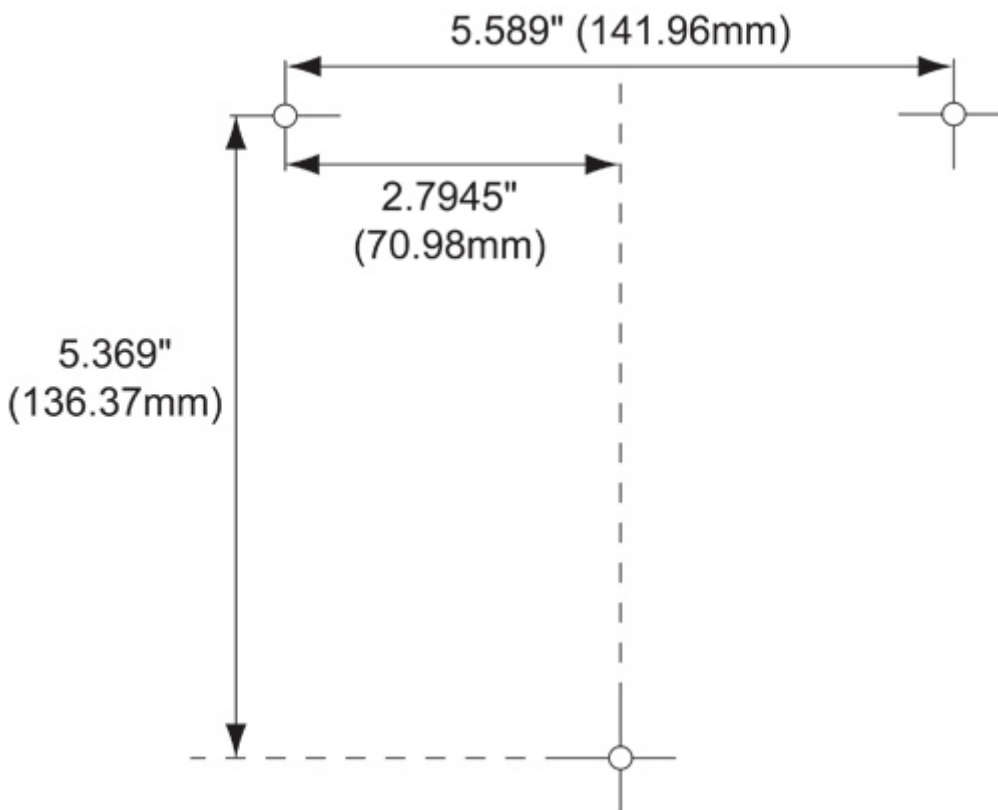

Media Selection

The following is a limited overview of media characteristics. For complete information and advice regarding your specific application needs, always consult a qualified media specialist or a Datamax Media Representative.

Media Selection – Direct Thermal

Consider three important factors when selecting direct thermal stock:

- > The abrasive qualities of the material that covers the thermal reactive layer of the paper.
- > The ability of that layer to control the chemical reaction that occurs when the image is “burned”.
- > The amount of heat required to create an image on the paper.

Print Quality Controls

The printer provides flexibility with a comprehensive set of print controls. Of these, the amount of heat applied by the printhead and the rate of media movement will have the most effect on the printed images. Low cost direct thermal stocks, for example, have raised reaction temperatures and therefore require higher heat values and slower print speeds to make a clear image on the media. In general, there are two standard methods to control print quality:

- > The first method is to change the ‘Print Control / Heat’ setting (also selectable as ‘Heat Setting’ in most labeling software programs). Increasing this value causes more energy to be transferred to the media, resulting in a darker image. Conversely, if the image is too dark, reduce this value.
- > The second method is to change the ‘Print Control / Print Speed’ setting (also selectable as ‘Print Speed’ in most software programs). Changing the print speed changes the amount of time the media is under the printhead. Slower speeds allow more time and control for energy transfer, while faster speeds will increase throughput, but may require higher heat settings.

You will find that printing barcodes and detailed images on less expensive direct thermal media at higher speeds can be tricky. At one heat setting, the images will fade and at the next higher heat setting, the images will bleed. This is because the reaction temperature of the media is so high that at higher rates of speed, it cannot react fast enough. To print fine images at higher speed, media with lower reaction or release temperatures are required. On the slower end of the print rate settings, crisper images are possible because the media is not being stretched beyond its limits.

For specific application information, consult your media specialist or a Datamax Media Representative. Or download our "A Brief Introduction to Media" whitepaper at www.datamaxcorp.com

Embedded Fonts

All character fonts available with the printer are described in this section. Each font has a name associated with it for use in programming. Human-readable fonts have numeric names.

Fonts 0 through 8 use the slash zero (Ø) conventions for distinguishing between the zero and the alphabetic O. The slash can be removed with the label formatting command z. These fonts are non-proportional (monospaced): all of the characters take up the same amount of space when printed.

The Triumvirate font number 9 is a proportional font; each character will take up a different amount of space when printed.

Font	Valid ASCII Characters (decimal)	Use with Record Structure Type
0	32-127,255	Internal Bit-Mapped Fonts
1	32-168, 171, 172, 225,255	
2	32-168, 171, 172, 225,255	
3	32, 35-38, 40-58, 65-90, 128, 142-144, 146, 153, 154, 156, 157, 165, 168, 225,255	
4	32, 35-38, 40-58, 65-90, 128, 142-144, 146, 153, 154, 156, 157, 165, 168, 225,255	
5	32, 35-38, 40-58, 65-90, 128, 142-144, 146, 153, 154, 156, 157, 165, 168, 225,255	
6	32, 35-38, 40-58, 65-90, 128, 142-144, 146, 153, 154, 156, 157, 165, 168, 225,255	
7	32-126	
8	32, 48-57, 60, 62, 67, 69, 78, 83, 84, 88, 90	Smooth Font
9	32-126, 128-169, 171-173, 181-184, 189, 190, 198, 199, 208-216, 222, 224-237, 241, 243, 246-250,255	

FONT	HEIGHT	WIDTH	SPACING
Font 0	7	5	1
Font 1	13	7	2
Font 2	18	10	2
Font 3	27	14	2
Font 4	36	18	3
Font 5	52	18	3
Font 6	64	32	4
Font 7	32	15	5
Font 8	28	15	5

Font 0 96-character alphanumeric, upper and lower case.

Font 0
 !"#\$%&'()*+,-./
 0123456789:;<=>?@
 ABCDEFGHIJKLMNOP
 QRSTUVWXYZ[\]^_`
 abcdefghijklmnop
 qrstuvwxyz{|}~

Font 1 145-character upper and lower case alphanumeric w/ descenders and ascenders.

Font 1:
 !"#\$%&'()*+,-./0123456789:;<=>?@
 ABCDEFGHIJKLMNOPQRSTUVWXYZ[\]^_`
 abcdefghijklmnopqrstuvwxyz{|}~
 ÇèéáàáçèéíîïËÆøŒóó
 öüÜÖø£Ø×fa iounÑ#Rz%kB

Font 2 138-character alphanumeric, upper and lower case.

Font 2:
 !"#\$%&'()*+,-./0123456789:;<=>?@
 ABCDEFGHIJKLMNOPQRSTUVWXYZ[\]^_`
 abcdefghijklmnopqrstuvwxyz{|}~
 ÇèéáàáçèéíîïËÆøŒóó
 öüÜÖø£Ø×fa iounÑ#Rz%kB

Font 3 62-character alphanumeric, uppercase.

FONT 3:
 #\$%&'()*+,-./0123456789:
 ABCDEFGHIJKLMNOPQRSTUVWXYZ
 ÇÀÆÓÜ£ØÑ¿B

Font 4 62-character alphanumeric, uppercase.

FONT 4:
 #\$%&'()*+,-./0123456789:
 ABCDEFGHIJKLMNOPQRSTUVWXYZ
 ÇÀÆÓÜ£ØÑ¿B

Font 5 62-character alphanumeric, uppercase.

FONT 5:
 #\$%&'()*+,-./0123456789:
 ABCDEFGHIJKLMNOPQRSTUVWXYZ
 ÇÀÆÓÜ£ØÑ¿B

Font 6 62-character alphanumeric, uppercase.

FONT 6:
 #\$%&'()*+,-./
 0123456789:
 ABCDEFGHIJKL
 MNOPQRSTUVWXYZ
 ÇÀÆÓÜ£ØÑ¿B

Font 7 OCR-A, size I.

Font 8 OCR-B, size III.

Font 7:
 !"#\$%&'()*+,-./
 0123456789:;<=>?@
 ABCDEFGHIJKLMNOP
 PQRSTUVWXYZ[\]^_`
 abcdefghijklmno
 pqrstuvwxyz{|}~

Font 8:
 0123456789
 <>CENSTXZ|

Font 9 Internal Triumvirate font.

Point sizes are selected by the number in the barcode height. Larger point sizes can be obtained by increasing the height and width multipliers, 48pt and 72pt fonts are generated by doubling the 24pt and 36pt fonts respectively (see the *Programmer's Manual* for more information)

6 pt ABCDEFGHIJKLMNOPQRSTUVWXYZabcdefghijklmnopqrstuvwxyz0123456789
 8 pt ABCDEFGHIJKLMNOPQRSTUVWXYZabcdefghijklmnopqrstuvwxyz?
 10 pt ABCDEFGHIJKLMNOPQRSTUVWXYZabcdefghijklmnopqrstuvwxyz
 12 pt ABCDEFGHIJKLMNOPQRSTUVWXYZabc
 14 pt ABCDEFGHIJKLMNOPQRSTUVWXYZ
 18 pt ABCDEFGHIJKLMNOPQR
 24 pt ABCDEFGHIJKLM
 30 pt ABCDEFGHIJ
 36 pt ABCDEFG
 48 pt ABCD

Embedded Bar Codes

Bar Code fonts have alpha names (left column in the table below). Uppercase alpha names will print barcodes with human-readable interpretations. Lowercase alpha names will print barcodes only. The table is followed by visual samples.

Barcode ID	Type	Length	Check-sum	Valid ASCII Characters, decimal value representation
A / a	Code 39	Varies	No	32, 36, 37, 42, 43, 45-57, 65-90
B / b	UPC-A (regular)	11	Yes	48-57 Numeric only Option V used in the 6th & 7th position
C / c	UPC-E (zero suppression)	6	Yes	48-57 Numeric only
D / d	Interleaved 2 of 5 (I 2 of 5)	Varies	No	48-57 Numeric only
E / e	Code 128	Varies	M-103	32-127
F / f	EAN-13	12	Yes	48-57 Numeric only. Option V used in the 7th & 8th position
G / g	EAN-8	7	Yes	48-57 Numeric only
H / h	Health Industry Bar Code (Code 39 Mod and 43 checksum)	Varies	M-43	32, 36-39, 42, 43, 45-57, 65-90
I / i	Codabar	Varies	No	36, 43, 45-58, 65-68
J / j	I 2 of 5 with modulo 10 checksum	Varies	M-10	48-57 Numeric only
K / k	Plessey	Up to 14	M-10	48-57 Numeric only. Option + is Last Character for Second M-11 checksum
L / l	ITF SCC-14/ I 2 of 5 Shipping Container Code	13	M-10	48-57 Numeric only
M / m	2 digit UPC addendum	2	Yes	48-57 Numeric only
N / n	5 digit UPC addendum	5	Yes	48-57 Numeric only
O / o	Code 93	Varies	No	35-38, 42-58, 65-90, 97-122
p	Postnet	Varies	Yes	48-57 Numeric only
Q / q	SSCC-18/Serial Shipping Container Code	19	Yes	48-57 Numeric only
R / r	UCC/EAN Code 128 K-Mart NON EDI bar code	18	Yes	48-57 Numeric only
S / s	UCC/EAN 128 Random Weight	34 +	Yes	48-57 Numeric only
T / t	Telepen	Varies	Yes	Alphanumeric
U	UPS MaxiCode	84	Yes	Alphanumeric
u	UPS MaxiCode with Byte Count	Specified	Yes	Alphanumeric
v	FIM	1	No	A, B, C, D
z	PDF417	Varies	Yes	All
Z	PDF417 with Byte Count	Specified	Yes	All
W1c	DataMatrix	Varies	Yes	All 8-bit values
W1C	DataMatrix with Byte Count	Specified	Yes	All 8-bit values
W1d	QR Code – Auto format	Varies	Yes	Alphanumeric
W1D	QR Code – Manual format	Varies	Yes	Single-byte or Kanji double-byte
W1f	Aztec	Varies	Yes	All 8-bit values
W1F	Aztec with Byte Count	Specified	Yes	All 8-bit values
W1G / g	USD-8 (Code 11)	Varies	Yes	45, 48-57
W1k	RSS (six types)	Varies	Yes	Numeric / Alphanumeric (type dependant)
W1R	UCC/EAN Code 128 K-MART NON EDI	18	Yes	48-57 Numeric only
W1t	TCIF Linked Barcode 3 of 9 (TLC39)	Varies	No	Alphanumeric
W1z	MicroPDF417	Varies	Yes	All 8-bit values
W1Z	MicroPDF417 with Byte Count	Specified	Yes	All 8-bit values

Barcode A Code 39



Barcode B UPC-A (regular)



Barcode C UPC-E (zero suppression)



Barcode D Interleaved 2 of 5



Barcode E Code 128



Barcode F EAN-13



Barcode G EAN-8



Barcode H Health Industry Bar Code (Code 39 Mod and 43 checksum)



Barcode I Codabar



Barcode J Interleaved 2 of 5 w/module 10 checksum



Barcode K Plessey



Barcode L ITF SCC-14/ I 2 of 5 Shipping Container Code



Barcode M 2 Digit UPC addendum **Barcode N** 5 Digit UPC addendum

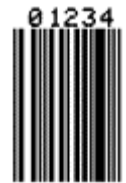

Barcode O Code 93



Barcode p Postnet



Barcode Q SSCC-18/Serial Shipping Container Code



Barcode R UCC/EAN Code 128 KMART NON EDI



Barcode S UCC/EAN 128 Random Weight



Barcode T Telepen



Barcode u UPS MaxiCode



Barcode v FIM



Barcode z PDF417



Bar Code W1c: DataMatrix



Bar Code W1d: QR Code



Bar Code W1f: Aztec



Bar Code W1g: USD-8 (Code 11)



Bar Code W1k: RSS
(Reduced Space Symbology)



Bar Code W1t: TCIF Linked Barcode 3 of 9
(TLC39)



Bar Code W1z: MicroPDF417



Glossary

alphanumeric Consisting of alphabetic, numeric, punctuation and other symbols.

backing material The silicon-coated paper carrier material to which labels with adhesive backing are affixed. Also referred to as “liner”.

bar code A representation of alphanumeric information in a pattern of machine-readable marks. The basic categories are divided into one-dimensional (UPC, Code 39, Postnet, etc.) and two-dimensional barcodes (DataMatrix, MaxiCode, PDF417, etc.).

burn line The row of thermal elements in the printhead that create the images on the media.

calibration The process through which sensor readings are entered into the printer for correct sensor function (for example, detection of a given media type) and TOF positioning.

character set The entire complement of alphanumeric symbols contained in a given font.

checksum An alphanumeric error detection method used in many bar code symbologies for informational security.

continuous media An uninterrupted roll or box of label or tag media that contains no gap, notch, or mark to separate individual labels or tags.

core diameter The inside diameter measurement of the cardboard core at the center of a media roll.

defaults The functional setting values returned following a factory reset of the printer.

diagnostics Programs used to locate and diagnose hardware problems.

die-cut media Media that has been cut into a pattern using a press, where the excess paper is removed leaving individual labels, with gaps between them, attached to a backing material.

direct thermal The printing method that uses a heat sensitive media and only the heat of the thermal printhead to create an image on the label.

direct thermal media Media coated with special chemicals that react and darken with the application of heat.

DPI (dots per inch) A measurement of print resolution, rated in the number of thermal elements contained in one inch of the printhead. Also referred to as “resolution”.

DPL (Datamax Programming Language) programming commands used specifically for control of and label production in Datamax printers. A complete listing of commands can be found in the *Programmer’s Manual*.

fan-fold Media that is folded and stacked.

feed speed The speed at which the media moves under the printhead in non-printed areas and between labels.

Flash memory Non-volatile memory (does not require printer power to maintain data) that can be erased and reprogrammed, used to hold the printer's operating programs.

font A set of alphanumeric characters that share a particular typeface.

gap A space between die-cut or notched labels used to sense the top of form.

IPS (inches per second) Imperial measurement of printer speeds.

label A paper or synthetic printing material, typically with a pressure sensitive adhesive backing.

label length The distance from the top of the label to the bottom of the label as it exits the printer.

label repeat The distance from the top of one label to the top of the next label.

label tracking Excessive lateral (side to side) movement of the media as it travels under the printhead.

label width The left to right measurement of the label as it exits the printer.

mark Generalized term to indicate the label top of form light.

media Generalized term for all types of printing stocks, including: roll fed, continuous, die-cut, reflective, and fanfold.

media hanger Device in the printer used to support roll media.

media sensor An electronic device equipped with photosensors to detect media and the top of form on die-cut, notched or reflective media.

notched stock Media, typically tag stock, with holes or notches in the material that is used to signal the top of form. The printer must be set to 'gap' to use this media type.

preprinted media Label stock that contains borders, text, or graphics, floodcoating, etc.

perforation Small cuts extending through the backing and/or label material to facilitate their separation. Also referred to as "perf".

print speed The speed at which the media moves under the printhead during the printing process.

reflective media Media imprinted with carbon-based black marks on the underside of the material, which is used to signal the top of form when the 'reflective' sensor is enabled.

registration Repeatable top to bottom alignment of printed labels.

reverse speed The backward rate of media motion into the printer during tear-off, peel and present and cutting operations for positioning the label at the start of print position.

roll media A form of media that is wound upon a cardboard core.

start of print The position on the label where the printing actually begins.

tag stock A heavy paper or synthetic printing material, typically featuring a notch or black mark for TOF and no adhesive backing.

TOF (top of form) The start of a new label as indicated by a label gap, notch, mark or programming.

void An undesirable blank space in a printed image.

ASCII Chart

	Char	Dec	Hex	Char	Dec	Hex	Char	Dec	Hex	Char	Dec	Hex
Ctrl @	NUL	0	00		32	20	@	64	40	`	96	60
Ctrl A	SOH	1	01	!	33	21	A	65	41	a	97	61
Ctrl B	STX	2	02	“	34	22	B	66	42	b	98	62
Ctrl C	EXT	3	03	#	35	23	C	67	43	c	99	63
Ctrl D	EOT	4	04	\$	36	24	D	68	44	d	100	64
Ctrl E	ENQ	5	05	%	37	25	E	69	45	e	101	65
Ctrl F	ACK	6	06	&	38	26	F	70	46	f	102	66
Ctrl G	BEL	7	07	'	39	27	G	71	47	g	103	67
Ctrl H	BS	8	08	(40	28	H	72	48	h	104	68
Ctrl I	HT	9	09)	41	29	I	73	49	i	105	69
Ctrl J	LF	10	0A	*	42	2A	J	74	4A	j	106	6A
Ctrl K	VT	11	0B	+	43	2B	K	75	4B	k	107	6B
Ctrl L	FF	12	0C	,	44	2C	L	76	4C	l	108	6C
Ctrl M	CR	13	0D	-	45	2D	M	77	4D	m	109	6D
Ctrl N	SO	14	0E	.	46	2E	N	78	4E	n	110	6E
Ctrl O	SI	15	0F	/	47	2F	O	79	4F	o	111	6F
Ctrl P	DLE	16	10	0	48	30	P	80	50	p	112	70
Ctrl Q	DC1	17	11	1	49	31	Q	81	51	q	113	71
Ctrl R	DC2	18	12	2	50	32	R	82	52	r	114	72
Ctrl S	DC3	19	13	3	51	33	S	83	53	s	115	73
Ctrl T	DC4	20	14	4	52	34	T	84	54	t	116	74
Ctrl U	NAK	21	15	5	53	35	U	85	55	u	117	75
Ctrl V	SYN	22	16	6	54	36	V	86	56	v	118	76
Ctrl W	ETB	23	17	7	55	37	W	87	57	w	119	77
Ctrl X	CAN	24	18	8	56	38	X	88	58	x	120	78
Ctrl Y	EM	25	19	9	57	39	Y	89	59	y	121	79
Ctrl Z	SUB	26	1A	:	58	3A	Z	90	5A	z	122	7A
Ctrl [Esc	27	1B	;	59	3B	[91	5B	{	123	7B
Ctrl \	FS	28	1C	<	60	3C	\	92	5C		124	7C
Ctrl]	GS	29	1D	=	61	3D]	93	5D	}	125	7D
Ctrl ^	RS	30	1E	>	62	3E	^	94	5E	~	126	7E
Ctrl _	US	31	1F	?	63	3F	_	95	5F		127	7F

Char	Dec	Hex	Char	Dec	Hex	Char	Dec	Hex	Char	Dec	Hex
Ç	128	80	á	160	A0		192	C0	Ó	224	E0
ü	129	81	í	161	A1		193	C1	ß	225	E1
é	130	82	ó	162	A2		194	C2	Ô	226	E2
â	131	83	ú	163	A3		195	C3	Ò	227	E3
ä	132	84	ñ	164	A4		196	C4	ö	228	E4
à	133	85	Ñ	165	A5		197	C5	Õ	229	E5
â	134	86	ª	166	A6	ã	198	C6	µ	230	E6
ç	135	87	º	167	A7	Ã	199	C7	¶	231	E7
ê	136	88	¸	168	A8		200	C8	þ	232	E8
è	137	89	®	169	A9		201	C9	Û	233	E9
è	138	8A		170	AA		202	CA	Ü	234	EA
ï	139	8B	1/2	171	AB		203	CB	Ù	235	EB
î	140	8C	1/4	172	AC		204	CC	ÿ	236	EC
ì	141	8D	¡	173	AD		205	CD	ÿ	237	ED
Ä	142	8E		174	AE		206	CE		238	EE
Å	143	8F	-	175	AF		207	CF		239	EF
É	144	90		176	B0	Ö	208	D0		240	F0
Æ	145	91		177	B1	Ð	209	D1	±	241	F1
Æ	146	92	²	178	B2	Ë	210	D2		242	F2
ô	147	93	³	179	B3	Ë	211	D3	¾	243	F3
ö	148	94	´	180	B4	Ë	212	D4		244	F4
ò	149	95	Á	181	B5		213	D5		245	F5
û	150	96	Â	182	B6	Í	214	D6	÷	246	F6
ù	151	97	Ã	183	B7	Î	215	D7	,	247	F7
ÿ	152	98	©	184	B8	Ï	216	D8	°	248	F8
Ö	153	99	ª	185	B9		217	D9	¨	249	F9
Ü	154	9A		186	BA		218	DA	·	250	FA
Ø	155	9B	»	187	BB		219	DB		251	FB
£	156	9C		188	BC		220	DC		252	FC
Ø	157	9D	¸	189	BD		221	DD		253	FD
x	158	9E	¥	190	BE	ì	222	DE		254	FE
f	159	9F		191	BF		223	DF	€	255	FF

Notes: For the hardware handshake XON/XOFF commands:

XON = Ctrl Q (DC1)
XOFF = Ctrl S (DC3)

The Euro € character has been added to the table above at 255 (FF) as a Datamax standard for resident bit-mapped fonts 0,1,2,3,4,5,6, and 9 (CG Triumvirate).

Important Safety Instructions

This printer has been carefully designed to provide many years of safe, reliable performance. As with all electrical equipment, there are a few basic precautions you should take to avoid hurting yourself or damaging the printer:

- > Carefully read the installation and operating instructions provided with your printer.
- > Read and follow all warning instruction labels on the printer.
- > Place the printer on a flat, firm, solid surface.
- > To protect your printer from overheating, make sure all openings on the printer are not blocked.
- > Do not place the printer on or near a heat source.
- > Do not use your printer near water, or spill liquid into it.
- > Be certain that your power source matches the rating listed on your printer. If you are unsure, check with your dealer or with your local power company.
- > Do not place the power cord where it will be walked on. If the cord becomes damaged or frayed replace it immediately.
- > Do not insert anything into the ventilation slots or openings on the printer.
- > Only qualified, trained service technicians should attempt to repair your printer.

Copyright Information

CG Triumvirate is a trademark of Agfa Corporation.

CG Times based upon Times New Roman under license from the Monotype Corporation.

Windows is a registered trademark of the Microsoft Corporation.

All other brand and product names are trademarks, service marks, registered trademarks, or registered service marks of their respective companies.

Firmware (Software) Agreement

The enclosed Firmware (Software) resident in the Printer is owned by Licensor or its suppliers and is licensed for use only on a single printer in the user's Trade or Business. **The User agrees not to, and not to authorize or permit any other person or party to, duplicate or copy the Firmware or the information contained in the non-volatile or programmable memory.** The firmware (Software) is protected by applicable copyright laws and Licensor retains all rights not expressly granted. In no event will Licensor or its suppliers be liable for any damages or loss, including direct, incidental, economic, special, or consequential damages arising out of the use or inability to use the Firmware (Software).

Information in this document is subject to change without notice and does not represent a commitment on the part of Datamax Barcode Products Corporation. No part of this manual may be reproduced or transmitted in any form or by any means, for any purpose other than the purchaser's personal use, without the expressed written permission of Datamax Corporation.

All rights reserved. Printed in the United States of America.

© Copyright 2006 by Datamax Corporation

Part Number: 88-2330-01

Revision: A

Agency Compliance and Approvals



UL60950 Information Technology Equipment
C22.2 No. 950-M93

EN60950



For 230 Volt Operation (Europe): Use a cord set, marked "HAR," consisting of a min H05VV-F cord which has a minimum 0.75 square mm diameter conductors, provided with an IEC 320 receptacle and a male plug for the country of installation rated 6A, 250V

Für 230 Volt (Europa): Benützen Sie ein Kabel, das mit "HAR" markiert ist, bestehend mindestens aus einem H05VV-F Kabel, das mindestens 0,75 Quadratmillimeter Drahtdurchmesser hat; sowie eine IEC320 Steckdose und einen für das Land geeigneten Stecker, 6A, 250 Volt.



As an Energy Star Partner, the manufacturer has determined that this product meets the Energy Star guidelines for energy efficiency.

The manufacturer declares under sole responsibility that this product conforms to the following standards or other normative documents:



EMC: EN 55022 (1993) Class A
EN 50024 (1998)

Safety: This product complies with the requirements of EN 60950-1, 1st Edition



Gost-R

FCC: This device complies with FCC CFR 47 Part 15 Class A.

Note: This equipment has been tested and found to comply with the limits for a Class A digital device, pursuant to Part 15 of the FCC Rules. These limits are designed to provide reasonable protection against harmful interference when the equipment is operated in a commercial environment. This equipment generates, uses, and can radiate radio frequency energy, and if not installed and used in accordance with the instructions in this manual, it may cause harmful interference to radio communications. Operation of this equipment in a residential area is likely to cause harmful interference in which case the user will be required to correct the interference at his own expense.

Datamax Barcode Products Limited Warranty Statement Ex2™ Printer

Printer

Datamax warrants to Purchaser that under normal use and service, the Ex2™ Printer, (with the exception of the thermal printhead) purchased hereunder shall be free from defects in material and workmanship for a period of (365) days from the date of shipment by Datamax.

Expendable and/or consumable items or parts such as lamps, fuses, labels and ribbons are not covered under this warranty. This warranty does not cover equipment or parts which have been misused, altered, neglected, handled carelessly, or used for purposes other than those for which they were manufactured. This warranty also does not cover loss, damages resulting from accident, or damages resulting from unauthorized service.

Thermal Printhead

This warranty is limited to a period of one year, (365 days), or 1,000,000 linear inches of use, whichever comes first, for the Ex2™ thermal printhead. This one year (365 days) warranty is valid only if a Datamax - approved thermal label media is used, as defined in the then current Datamax list of approved thermal/thermal transfer media, a copy of which is available from Datamax. Failure to use Datamax-approved media is justification for invalidation of this thermal printhead warranty. This warranty does not cover printheads which have been misused, altered, neglected, handled carelessly, or damaged due to improper cleaning or unauthorized repairs.

Warranty Service Procedures

If a defect should occur during the warranty period, the defective unit shall be returned, freight and insurance prepaid, in the original shipping containers, to Datamax at: 4501 Parkway Commerce Blvd., Orlando, Florida, 32808. A Return Material Authorization (RMA) number must be issued before the product can be returned. To open an RMA please call the Datamax Customer Service Department at (407) 523-5550. Please include your RMA number on the outside of the box and on the shipping document. Include a contact name, action desired, a detailed description of the problem(s), and examples when possible with the defective unit. Datamax shall not be responsible for any loss or damages incurred in shipping. Any warranty work to be performed by Datamax shall be subject to Datamax's confirmation that such product meets Datamax warranty. In the event of a defect covered by its warranty, Datamax will return the repaired or replaced product to the Purchaser at Datamax's cost.

With respect to a defect in hardware covered by the warranty, the warranty shall continue in effect until the end of the original warranty period, or for sixty (60) days after the repair or replacement, whichever is later.

General Warranty Provisions

Datamax makes no warranty as to the design, capability, capacity or suitability of any of its hardware, supplies, or software.

Software is licensed on an "as is" basis without warranty. Except and to the extent expressly provided in this warranty and in lieu of all other warranties, there are no warranties, expressed or implied, including, but not limited to, any warranties of merchantability or fitness for a particular purpose.

Purchaser shall be solely responsible for the selection, use, efficiency and suitability of Datamax's products.

Limitation of Liability

In no event shall Datamax be liable to the purchaser for any indirect, special or consequential damages or lost profits arising out of or relating to Datamax's products, or the performance or a breach thereof, even if Datamax has been advised of the possibility thereof. Datamax's liability, if any, to the purchaser or to the customer of the purchaser hereunder shall in no event exceed the total amounts paid to Datamax hereunder by the purchaser for a defective product.

In no event shall Datamax be liable to the purchaser for any damages resulting from or related to any failure or delay of Datamax in the delivery or installation of the computer hardware, supplies or software or in the performance of any services.

Some states do not permit the exclusion of incidental or consequential damages, and in those states the foregoing limitations may not apply. The warranties here give you specific legal rights, and you may have other legal rights which vary from state to state.

Contact Datamax

Datamax Technical Support

We can help! If you are having technical problems with a Datamax product, please do not hesitate to contact us. Our Technical Support Specialists are available to provide you technical solutions before, during, and after the sale and delivery of a Datamax product.

Please choose a location nearest to you.

Datamax Corporate Headquarters
Orlando, FL USA
Monday - Friday
8:00am - 6:00pm EST
Tel: 407-523-5540
Fax: 407-523-5542

Datamax International
Harlow, Essex UK
Monday - Friday
0830 - 1700 GMT
Tel: +44 (0) 1279 772233
Fax: +44 (0) 1279 772249

Datamax Latin America
Orlando, FL USA
Monday - Friday
8:00am - 5:00pm EST
Tel: 407-523-5540
Fax: 407-523-5542

Datamax Asia-Pacific
Singapore
Monday - Friday
0830 - 1730
Tel: +65 6542 2611
Fax: +65 6542 3611

Recommended Spares List

Part Number	Description
DPO51-2424-00	CCA, MAINBOARD 4MB FLASH (1/PK)
DPO51-2424-20	CCA, MAINBOARD 8MB FLASH (1/PK)
DPO51-2424-30	CCA, MAINBOARD 8MB FLASH w/LAN (1/PK)
DPO20-2192-01	PRINTHEAD (1/PK)
DPO15-3155-01	KIT, PLATEN ROLLER (5/PK)
DPO17-2436-01	SCREW, M3 X 8 THRD CUT OVAL (50/PK)
DPO50-2050-01	POWER SUPPLY, 24VDC, 3 AMPS (1/PK)

For ordering information contact Datamax Customer Support at 407-578-8007 or email at customercare@datamaxcorp.com